

Schematic Circuit of Chassis for Nos. 10 and 11 Receivers

1930-31

STROMBERG-CARLSON

Type	Tube Position	"A" Vts.	"B" Vts.	"C" Vts.	Screen Vts.	Screen Current	Cath. Vts.	No.1 MA.	Grid Test MA.
'24	1 R.F.	2.2	120	0.2	71	.7	2.0	3.5
'24	2 R.F.	2.25	117	0.2	70	1.0	2.5	4.0
'24	3 R.F.	2.25	115	1.0	70	0.7	2.4	3.5
'24	Det.	2.2	175	1.0	52	0.2	1.3
'45	{ I.A.F. }	2.3	205	39.0	25.0	35.0
'45	{ P.P. }	2.3	205	39.0	25.0	35.0

LV-112.
LVS-High
Vol. Con. Max

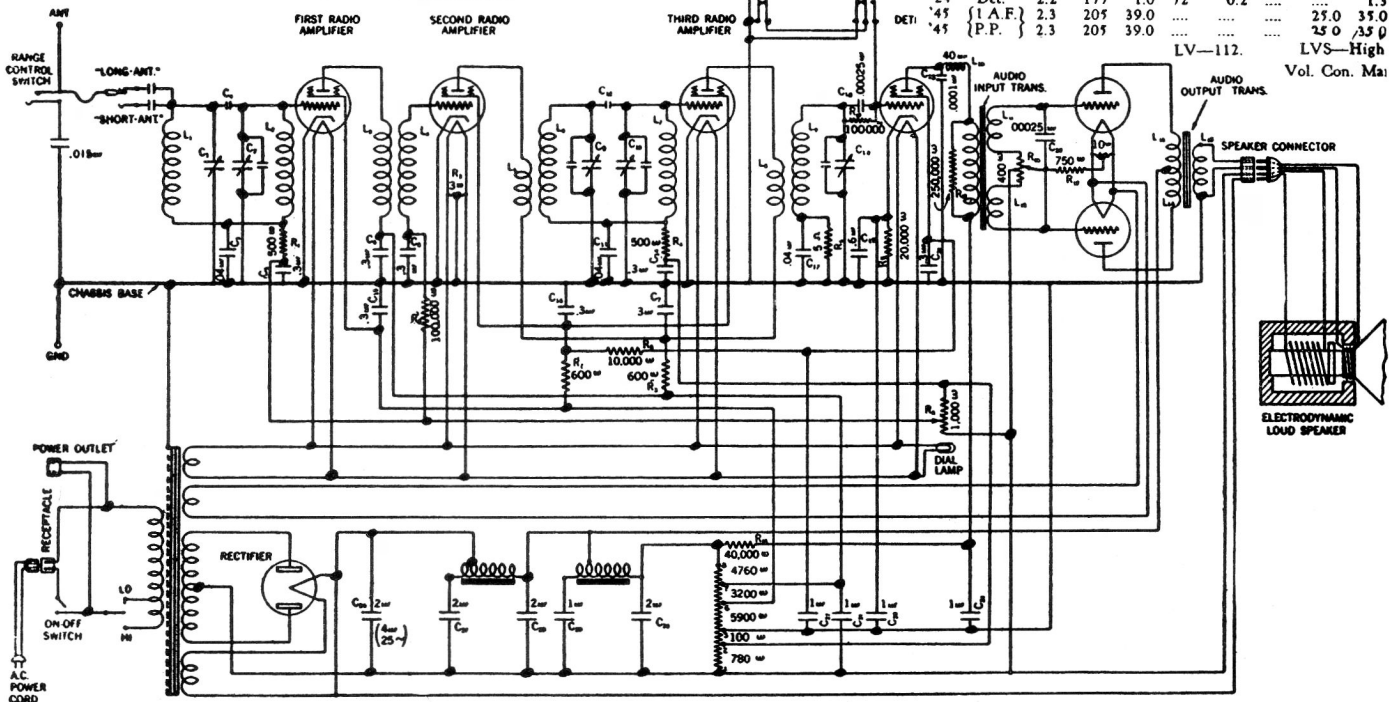

Nos. 12 and 14 Receivers

1930-31

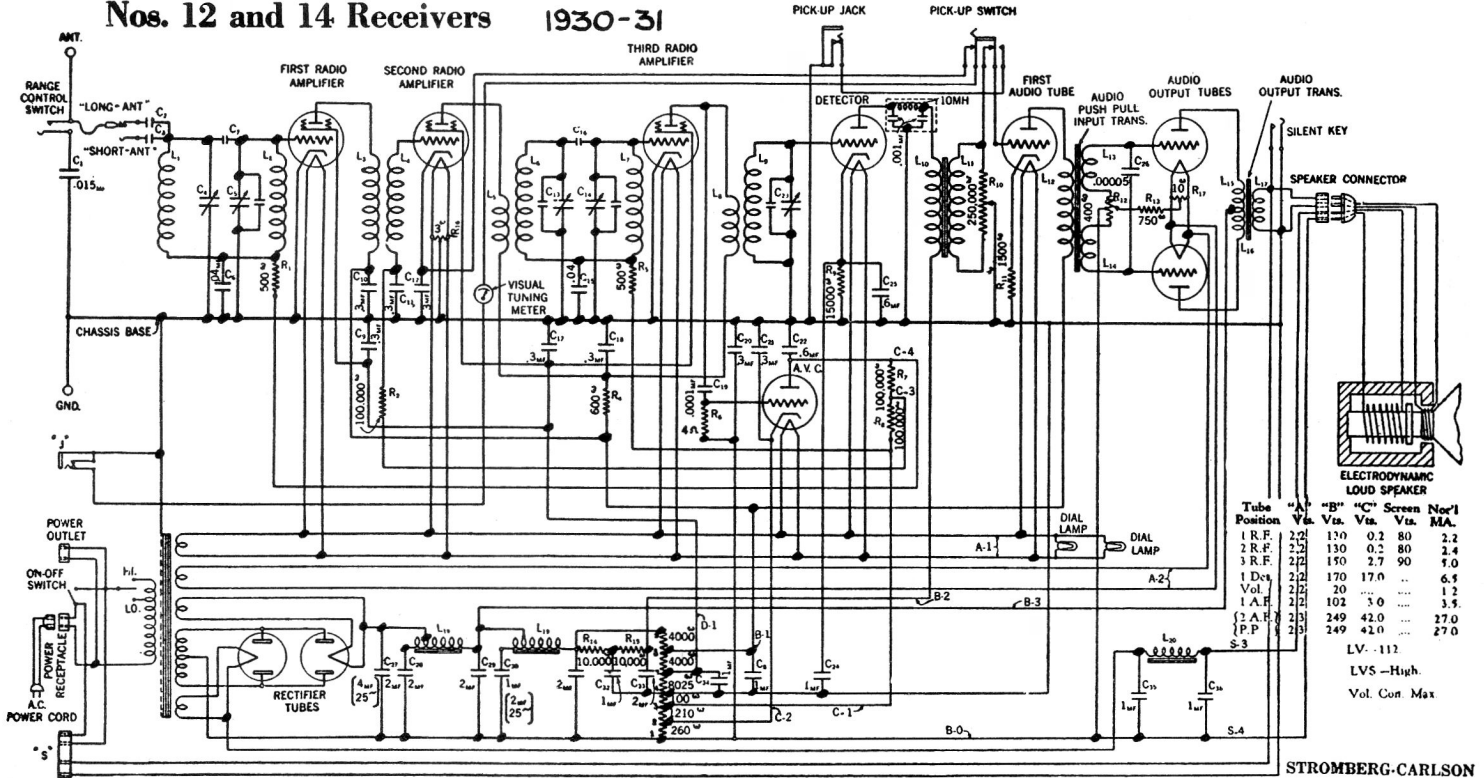

Tube Position	"A" Vts.	"B" Vts.	"C" Vts.	Screen Vts.	No.1 MA.	Grid Test MA.
1 R.F.	2.2	130	0.2	80	2.2
2 R.F.	2.2	130	0.2	80	2.4
3 R.F.	2.2	150	2.7	90	5.0
1 Det.	2.2	170	17.0	6.5
Vol.	2.2	20	1.2
I.A.F.	2.2	102	5.0	3.5
{ I.A.F. }	2.3	249	42.0	17.0
{ P.P. }	2.3	249	42.0	27.0

LV-112.
LVS-High.
Vol. Con. Max

STROMBERG-CARLSON