

**ROGERS MAJESTIC R167, R177**  
**DE FOREST D567, D577**

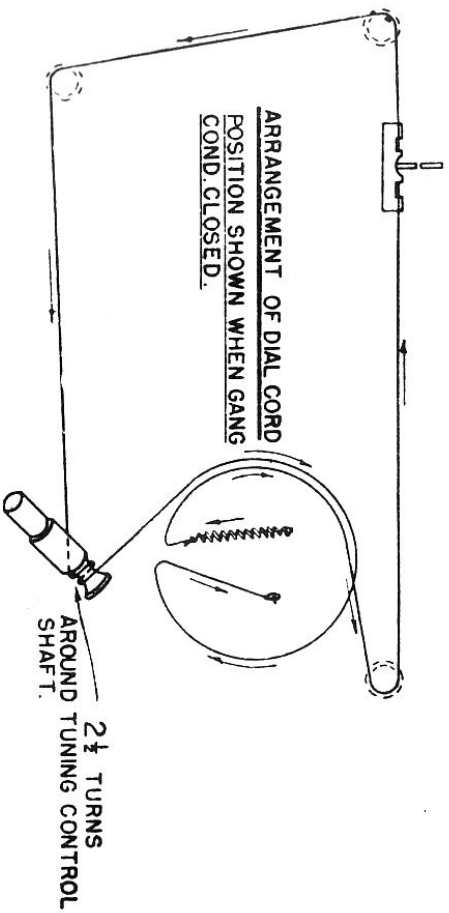

SIGNAL GENERATOR

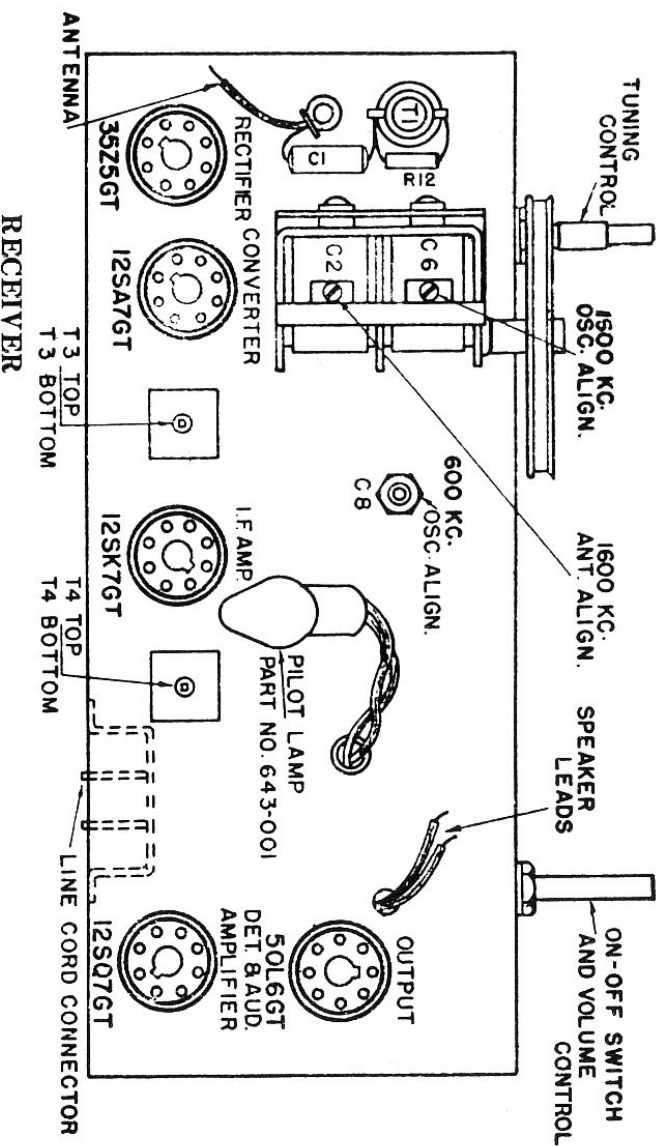

Operation Steps	Connections to Receiver	Frequency	Tuning Capacitor	See Notes	Adjust in Stated Order for Maximum Output
1	To 12SK7GT Control grid (4) through .05 mfd. capacitor	455 kc.	Min.		2nd I.F. Transformer T4 Bottom — Top
2	To Stator of C3 through .05 mfd. capacitor	455 kc.	Min.	A	1st I.F. Transformer T3 Top — Bottom
3	To Antenna Contact through 200 mmf. capacitor	1600 kc.	1600 kc.		Oscillator Trimmer C6 Antenna Trimmer C2
4	To Antenna Contact through 200 mmf. capacitor	600 kc.	600 kc.	B	Oscillator Padder C8

NOTE A: After completing operation No. 2, do not attempt to repeak T4.

NOTE B: After completing operation No. 4, return to 1600 kc. and repeat operation 3, then repeat operation 4.

**ROGERS MAJESTIC**  
R167, R177

**DE FOREST**  
D567, D577