

C1	1A 3	25 2	2A	4	5-6	7	8	23 9	10	22	11-12	13-14	21	20	15-16	19	18
R1	1	2	3	4	5	6-7-8	27	9-10-11	13	14-15-16-17-25	18-19-20-24	21-22	23				

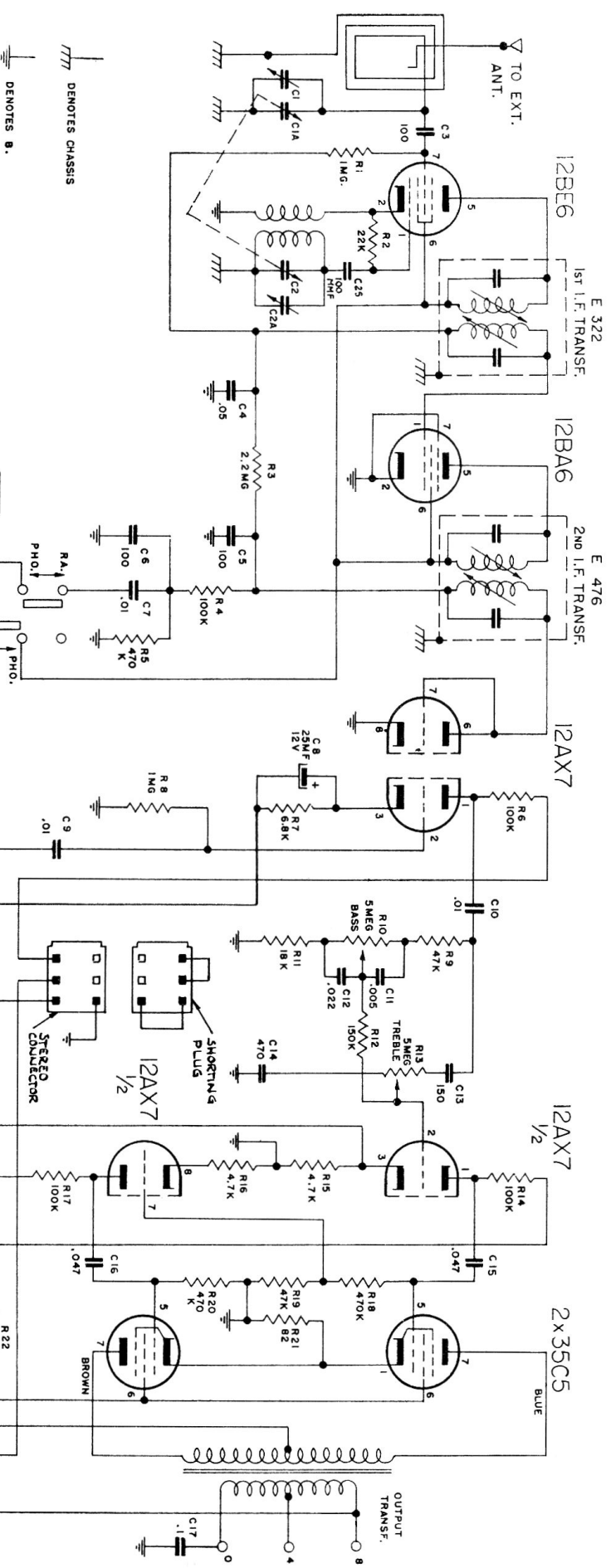

ALIGNMENT DATA

1. Set Phono-Radio switch to radio position.
2. Connect output meter across voice coil or VTVM from AVC line to B minus.
3. Connect signal generator through 0.1 MF to pin No. 7 on 12BE6 tube socket (control grid) apply 455 Kc signal, modulated at 30%.
4. Adjust I.F. No. 1 and No. 2 for maximum output in the following order:
 - a. I.F. No. 2 bottom
 - b. I.F. No. 2 top
 - c. I.F. No. 1 bottom
 - d. I.F. No. 1 top

5. Couple signal generator to the rod antenna by feeding signal to 2-3 turns of insulated wire, 6" in diameter and keeping this loop from rod antenna at a distance of 12".
6. Apply 1500Kc signal, modulated at 30%, turn tuning condenser to 1500 Kc mark on the dial and adjust oscillator trimmer (C7) located on the gang condenser.
7. Apply 1400 Kc signal, turn tuning condenser to 1400 Kc mark on the dial and adjust antenna trimmer (C2) located on the gang condenser.

NOTE : During entire aligning procedure, keep signal generator output at minimum.

Fleetwood 2012, 2014

