

FOR ANALYZER READINGS SEE SHEET. 4.

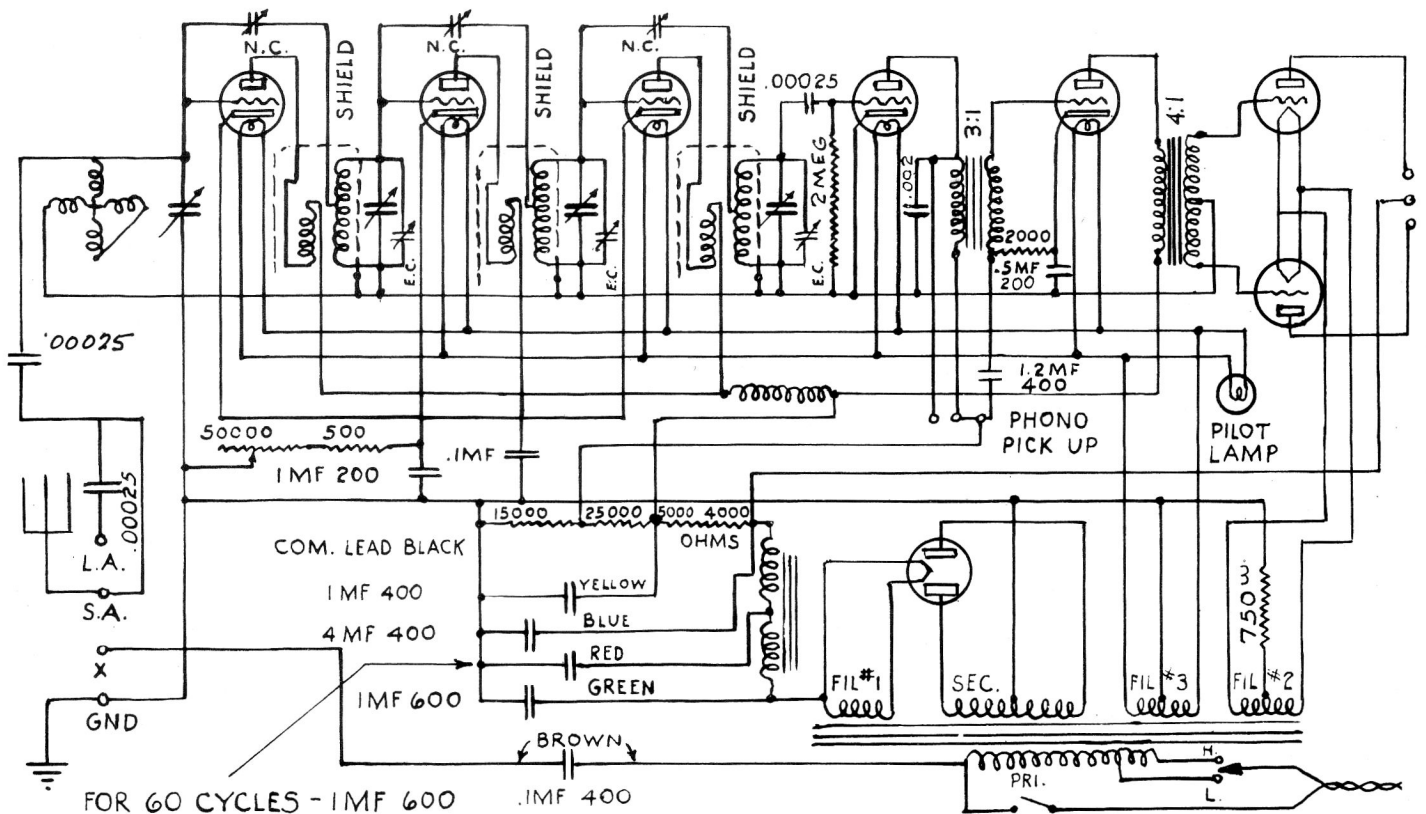

SEE SHEET. 4.