

- C 3 - 400 KC ANT ALIGNING
- C 4 - 5000 KC
- C 5 - 17800 KC
- C 7 - 400 KC R.F. ALIGNING
- C 8 - 5000 KC
- C 9 - 17800 KC
- C 11 - 400 KC OSC ALIGNING
- C 12 - 5000 KC
- C 13 - 17800 KC
- C 15 - 600 KC OSC ALIGNING
- C 16 - 1800 KC
- C 17 - 6900 KC
- C 18 - 450 KC 1st I.F. ALIGNING
- C 19 - 1800 KC
- C 20 - 450 KC 2nd I.F. ALIGNING
- C 21 - 450 KC 2nd I.F. ALIGNING
- C 23 - 450 KC 2nd I.F. ALIGNING

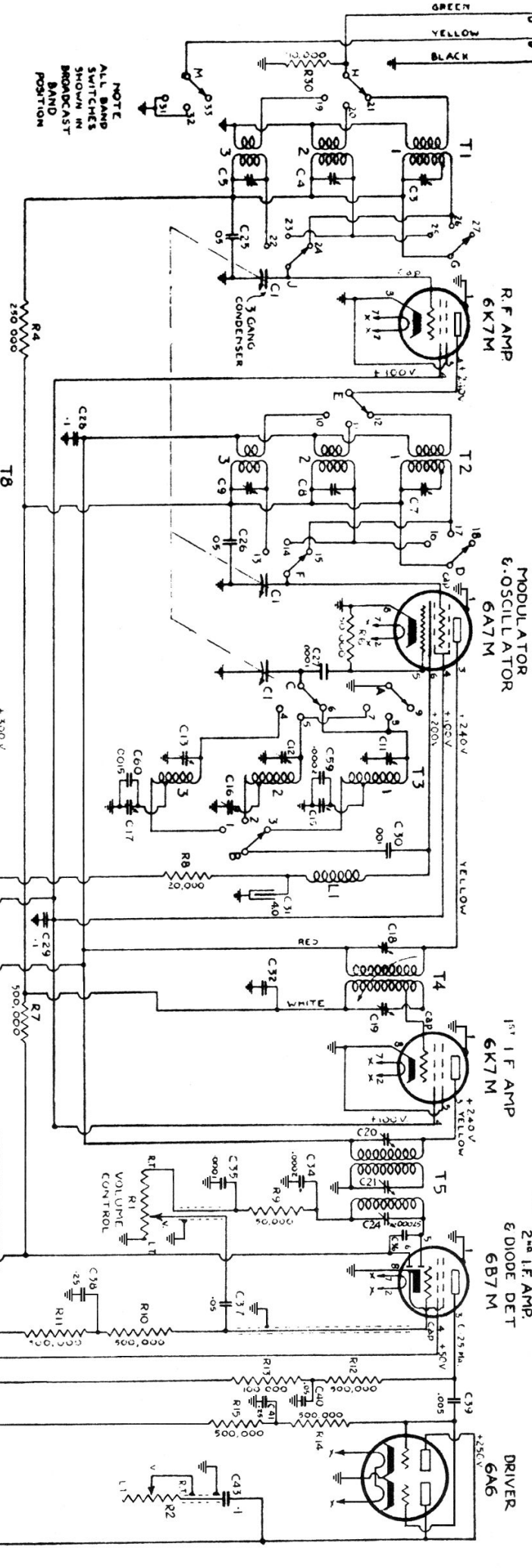

NOTE
ALL BAND
SWITCHES
SHOWN IN
BROADCAST
BAND
POSITION

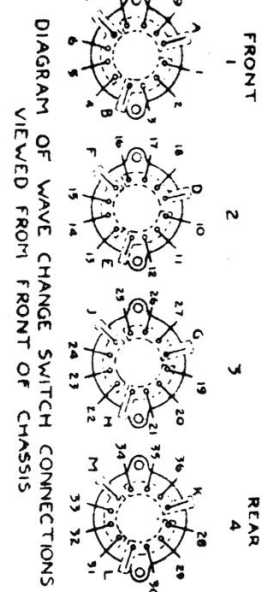
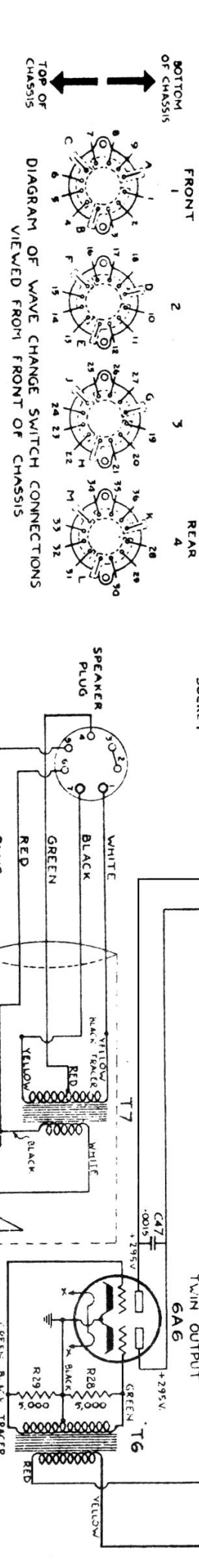
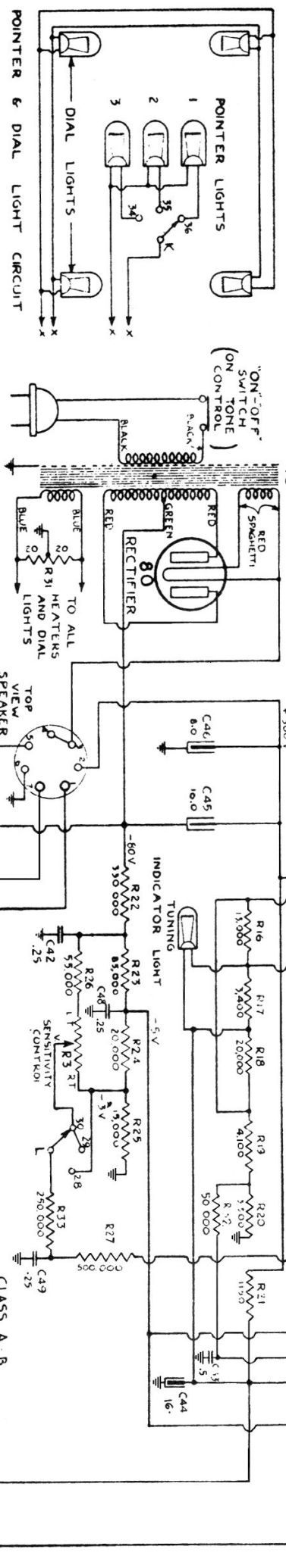

TOP OF CHASSIS
BOTTOM OF CHASSIS
FRONT
REAR

De Forest Crosley "Duchess" & "Empress"

(Chassis Type 76)

De Forest "Duchess" & "Empress" (Chassis Type 76)

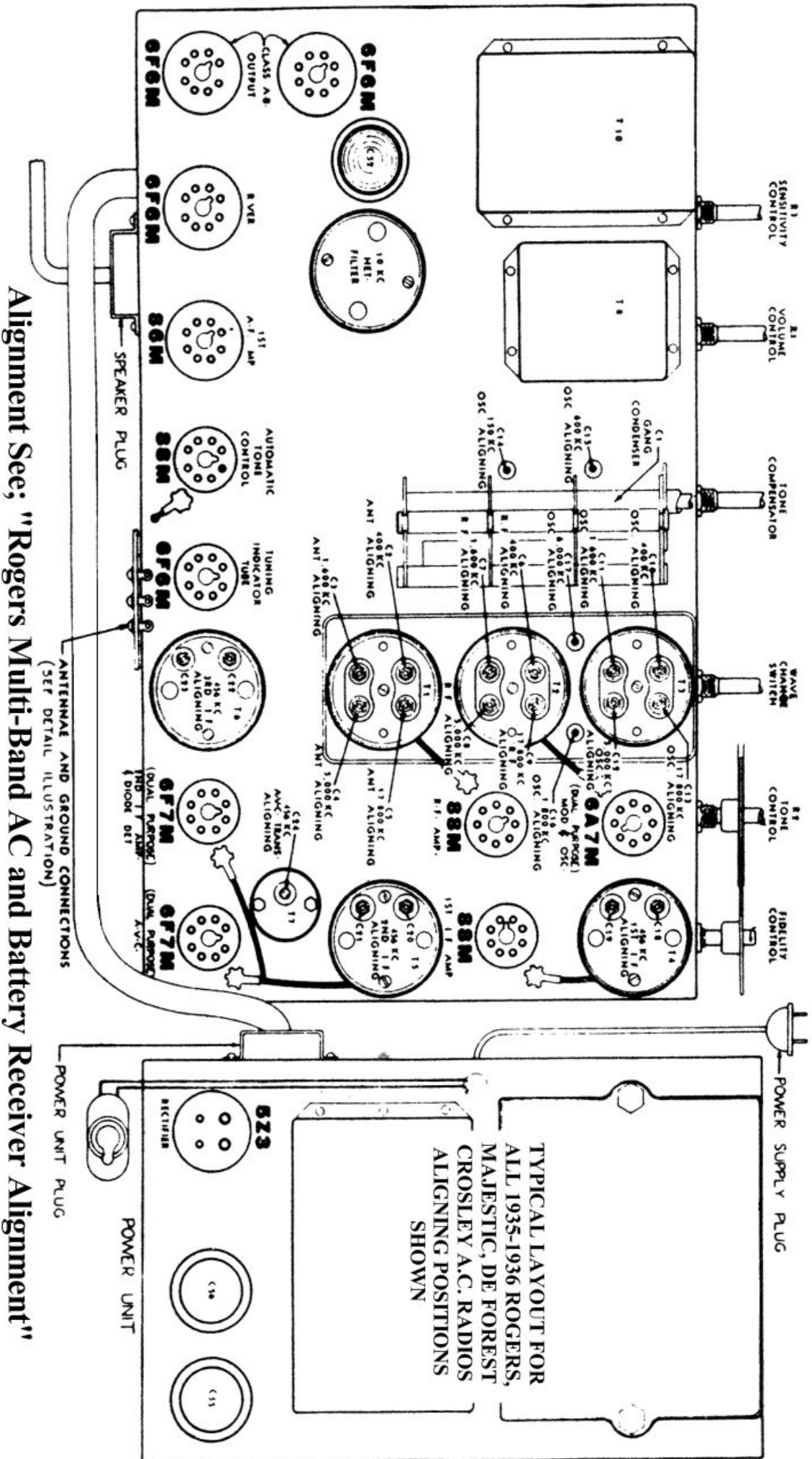

Alignment See; "Rogers Multi-Band AC and Battery Receiver Alignment"