

1929-30
Models
55, 55C

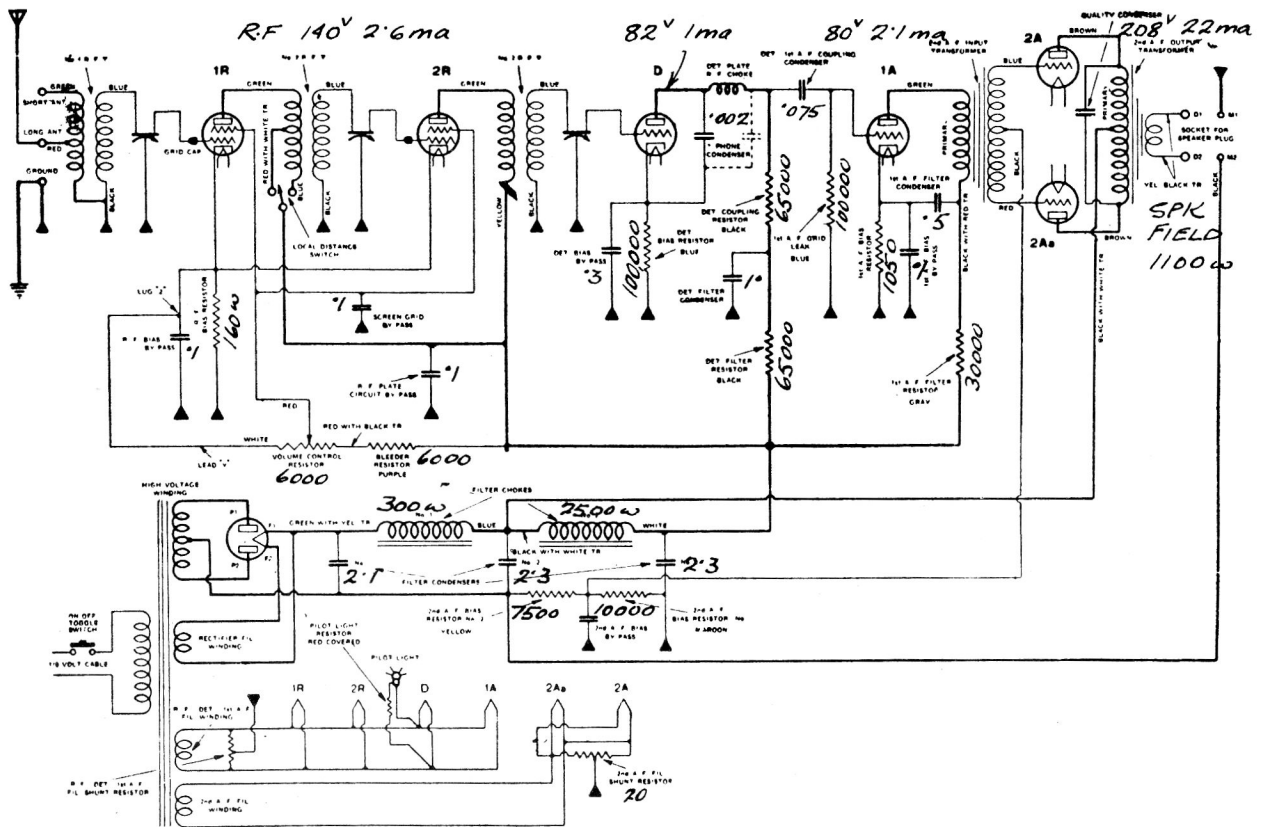

CIRCUIT DIAGRAM OF EARLY MODEL 55 AND 55-C WITH TRANSFORMER-COUPLED R. F. COILS.
In some Model 55 and 55-C, a double "phone" condenser is used. In later Model 55 and 55-C the "phone" condenser is of the single type.
For changes in the filament circuits, refer to Dealer Service Bulletin 6 of October 22, 1929.

1929-30
Models
55 and 55C

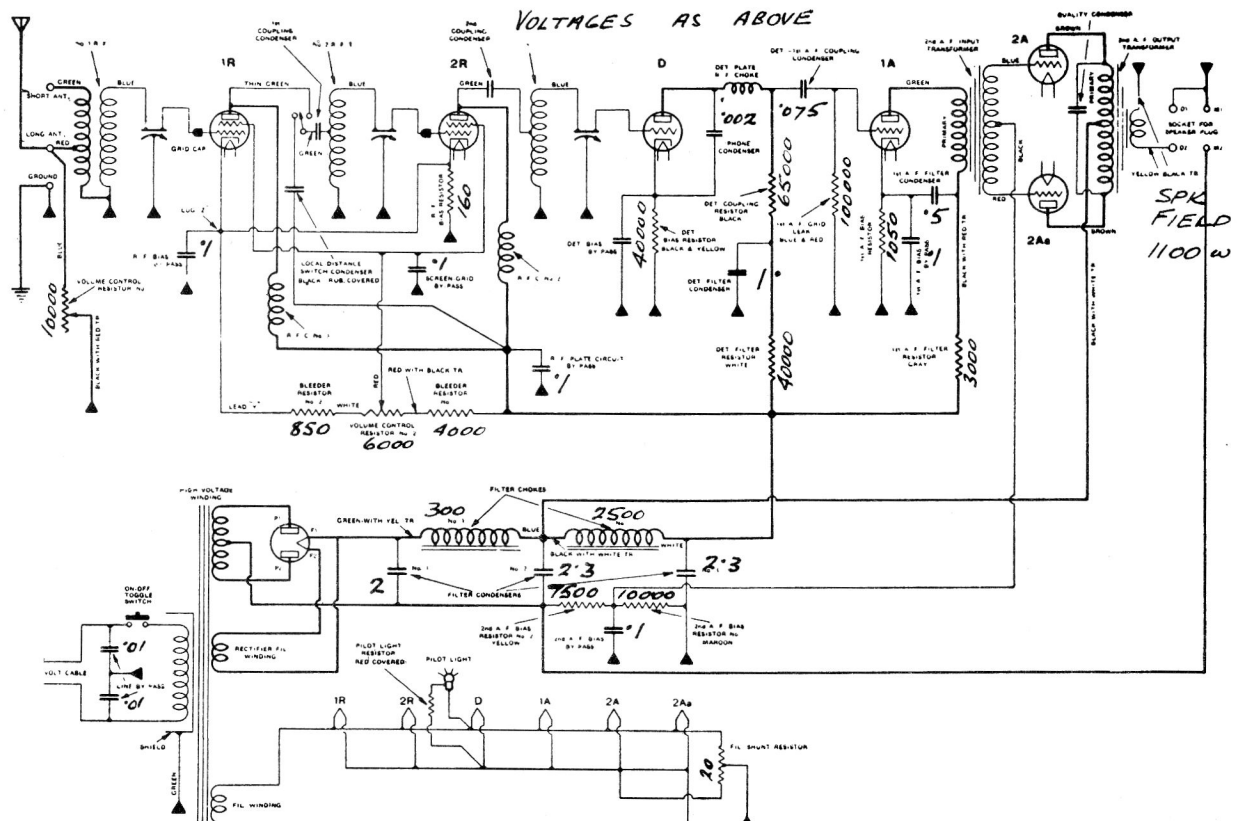

DIAGRAM OF LATER MODEL 55 AND 55-C WITH CAPACITY-COUPLED R. F. TRANSFORMERS.
The changes shown above were made gradually, not all at one time

Printed in Canada

—Courtesy Atwater Kent Mfg.