

Addison 55

K = 1,000Ω
M = 1,000,000Ω

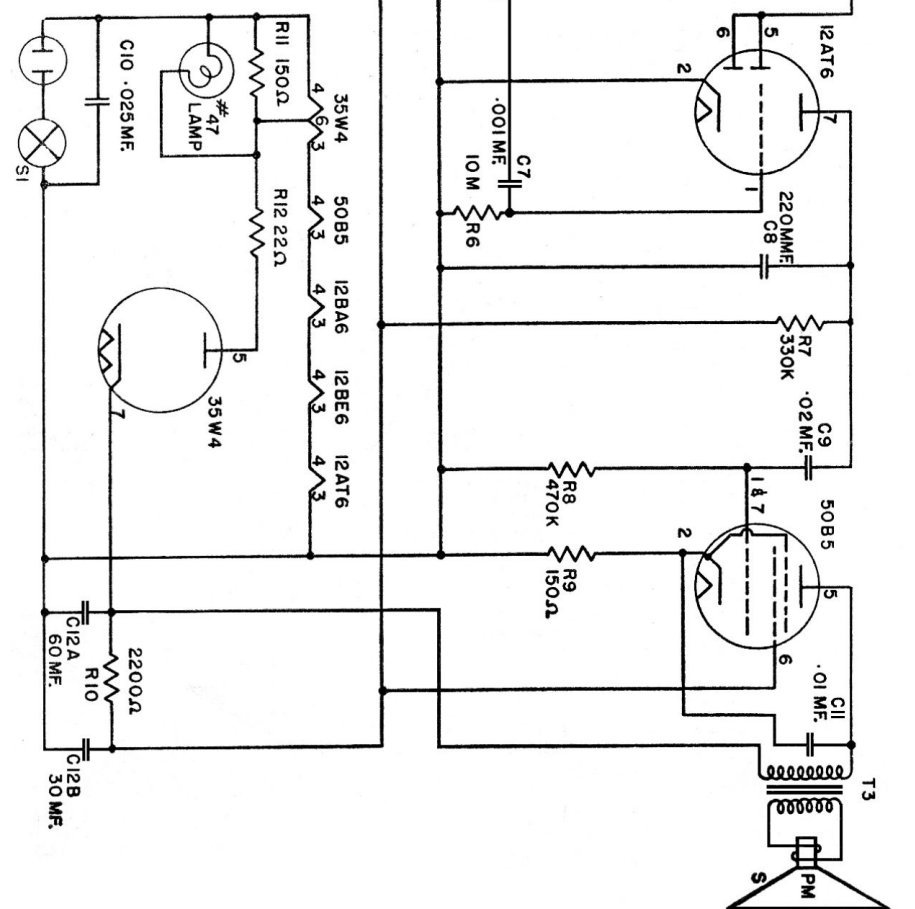

TUNING I.F. AMPLIFIER TO 455 KILOCYCLES

- (a) Connect the output from the Signal Generator through a 200 mmfd. mica condenser to antenna wire on the rear of the loop.
- (b) Connect the Output Meter across the speaker voice coil.
- (c) Turn the volume control to its maximum clockwise position and the tuning condenser so that the plates are completely in mesh.
- (d) Adjust Signal Generator to a setting of 455 Kilocycles.
- (e) Adjust iron cores located at the top and bottom of 2nd I.F. Transformer (T2) until maximum deflection is obtained on the Output Meter.
- (f) Adjust iron cores located at the top and bottom of 1st I.F. Transformer (T1) until maximum deflection is obtained on the Output Meter.

N.B. After each adjustment has been made it may be necessary to re-adjust the Signal Generator to give reasonable output.

BROADCAST BAND ALIGNMENT

- (a) Leave the Generator and Output Meter connected as described in the tuning of the I.F. amplifier.
- (b) Adjust the Signal Generator to 1500 K.C. Set dial to 1500 K.C.
- (c) Adjust the oscillator trimmer on the tuning condenser until maximum deflection is obtained on the Output Meter.
- (d) Now adjust the mixer trimmer on the tuning condenser until maximum deflection is obtained.
- (e) If adjustment should be necessary at the low frequency end of the broadcast band, bend the slotted sections on the mixer section of the tuning condenser for maximum output.



ADDISON 55