

ULTRATONE M-4W

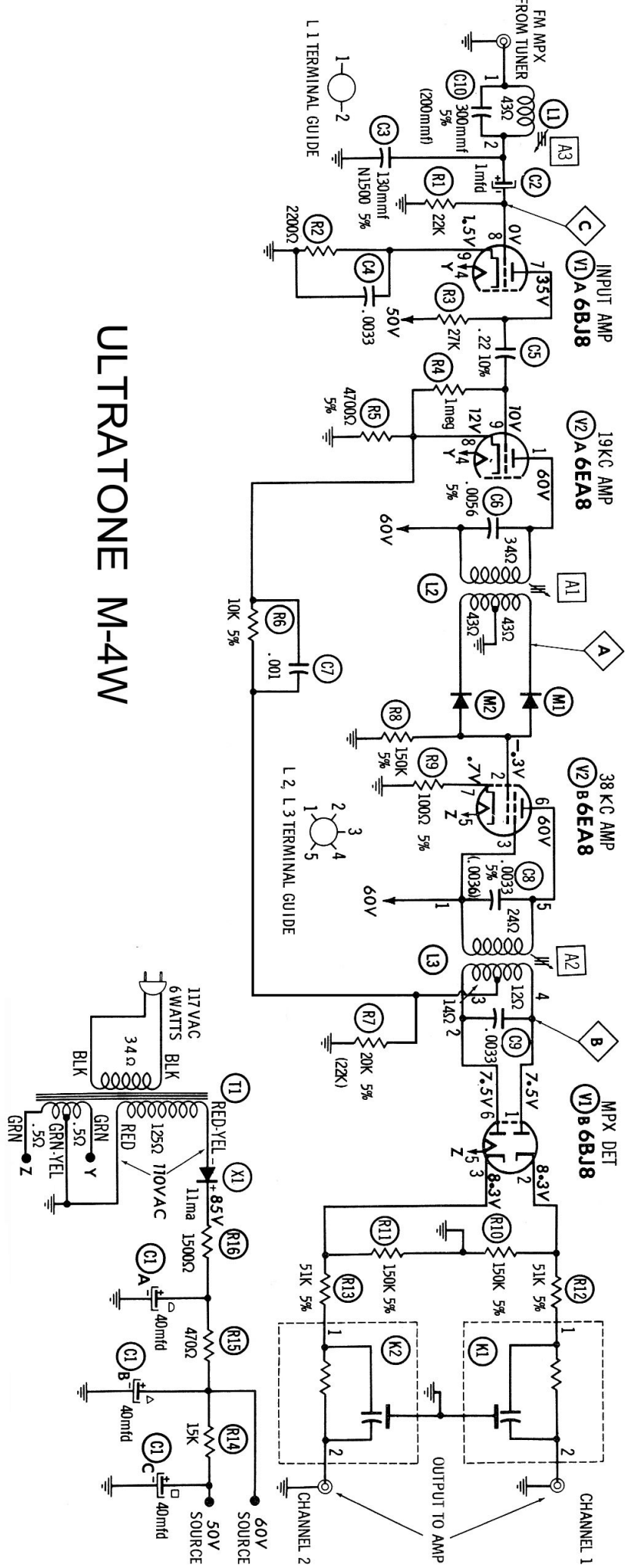

ULTRATONE M-4W

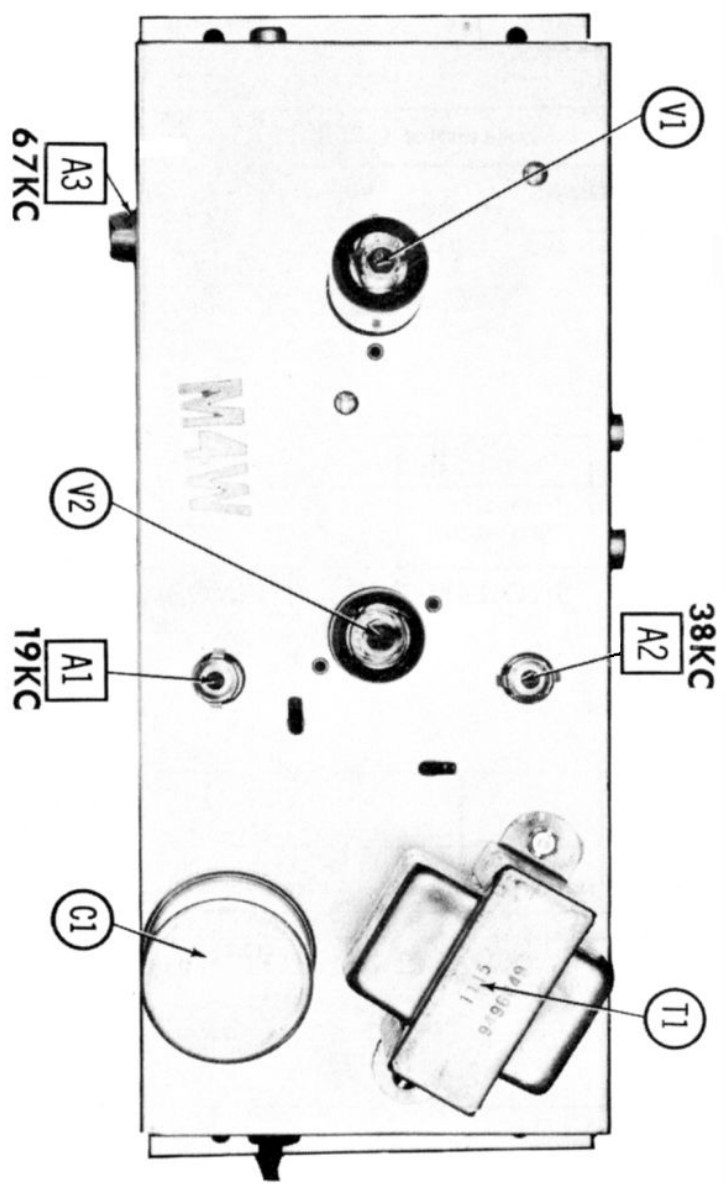

F M STEREO MULTIPLEX ALIGNMENT USING F M STEREO SIGNAL GENERATOR (\pm . 0001%) ACCURACY)

GENERATOR FREQUENCY	DIAL SETTING	INDICATOR	ADJUST	REMARKS
19KC	Vert. Amp. of scope thru 47K to point \diamond A, low side to ground.	\diamond A	A1	Adjust for maximum. Set scope to lock in 2 cycles of 19KC waveform.
"	Vert. Amp. thru 47K to point \diamond B, low side to ground.	\diamond B	A2	Adjust for maximum 4-cycle waveform.
67KC	Vert. Amp. to point \diamond C, low side to ground.	\diamond C	A3	Use Audio Oscillator if necessary. Adjust for MINIMUM

To align multiplex section using an air signal, first make sure FM section is properly aligned. Tune in a strong FM stereo signal. Follow steps 1 thru 3 above except in step 3 adjust to eliminate whistle or interference.