

Stromberg-Carlson Model 151 Schematic, Alignment Adjustments & Chassis Layout

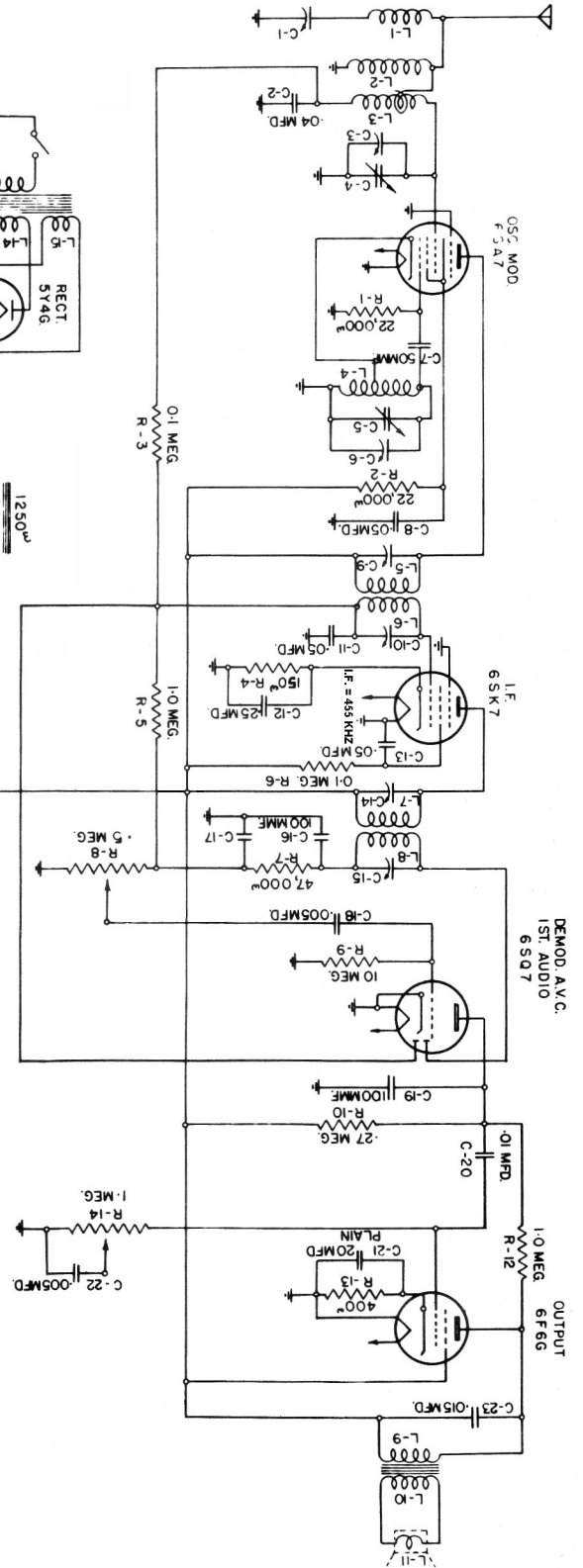

Aligning Procedure (follow this order exactly)

- I. Dial Pointer Adjustment.
 1. With the plates of the gang tuning capacitor fully engaged, set the dial pointer directly parallel with the junction of blue and white portion of the dial.
- II. Intermediate Frequency Adjustments.
 1. Tune set to extreme low frequency position. (.54 megacycles on dial scale).
 2. Connect the ground terminal of the signal generator to the ground binding post of the receiver.
 3. Introduce a modulated signal of 455 kilocycles, using a 0.1 microfarad capacitor in series with the lead from the signal generator to the grid terminal (No. 8) of the 6SA7 tube.
 4. Adjust the I. F. Aligners for maximum output in the following order:
 - a. Secondary of Second I. F. Transformer.
 - b. Primary of Second I. F. Transformer.
 - c. Secondary of First I. F. Transformer.
 - d. Primary of first I. F. Transformer.
- III. Wave Trap Adjustment.
 1. Tune set to 1,000 kilocycles.
 2. Leave the ground terminal of the signal generator connected to the ground binding post of the receiver.
 3. Introduce a fairly strong modulated signal of 455 kilocycles to the antenna binding post using a 200 mmfd. capacitor in series with the lead from the signal generator.
 4. Adjust the wave trap aligner for **minimum** signal.
- IV. Radio Frequency Adjustments.
 1. Leave the signal generator connected in the same way as for the wave trap alignment).
 2. Set the signal generator's frequency and the receiver's tuning dial to 1.5 megacycles.
 3. Check calibration and sensitivity at .6 megacycles on tuning dial.

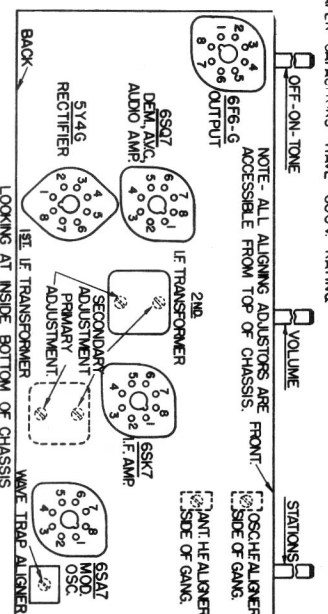

NORMAL VOLTAGE READINGS

Use a good high resistance voltmeter having a resistance of at least 1000 ohms per volt. Take all D. C. voltage readings on the 600 volt scale except where an asterisk appears. Take all readings with chassis operating and tuned to 1000 Kc.—no signal. Use a line voltage of 120 volts or make allowance for the variation. Read from indicated socket terminals to chassis base. Read from indicated socket terminals to chassis base. See Voltage Chart for position of terminals. A. C. Voltages are indicated by italics.

Table	Circuit	1	2	3	4	5	6	7	8	Header Voltage
6SA7	Mod.—Osc.	0	0	+205	+70—1.25*	6.3	—	6.3	—	Socket Terminal No. 10 A. C. 2-7 6.3
6SK7	I. F. Amp.	0	0	—	+11*	+55	6.3	+205	2-7	6.3
6SK7	Dem.—A. V. C.	0	0	0	0	0	0	+100	6.3	0 7-8 6.3
6F66	Output	0	0	+200	+205	—	6.3	+11*	2-7	6.3
5Y4G	Rectifier	0	0	265	—	+265	+265	7-8	5	

*Read on lowest possible scale of voltmeter.
Total Rectified D. C. current is 51 milliamperes.
Drop across Field Coil is 65 volts.