

Sparton 6048 & 6049

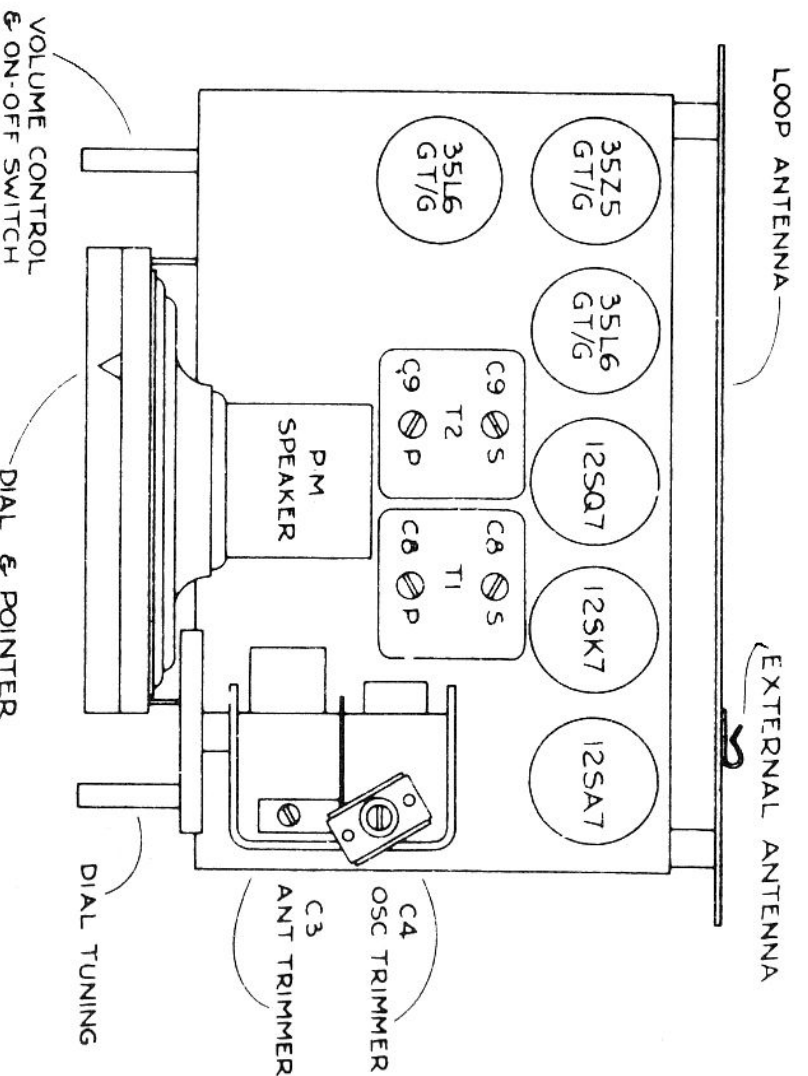
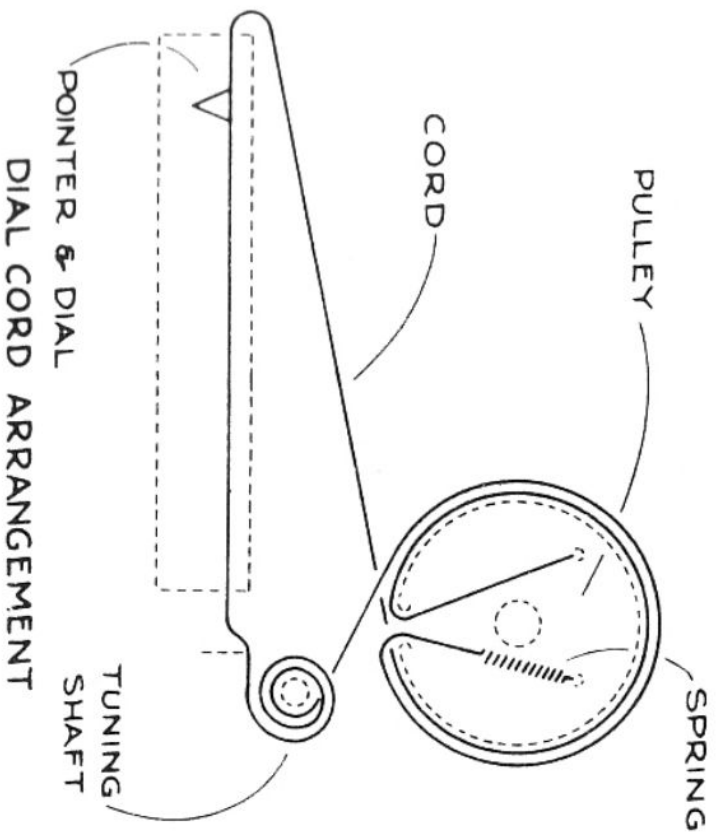

Sparton 6048 & 6049

ELECTRICAL ALIGNMENT

- Adjust Signal Generator to 455 Kcs and connect to Antenna Post and Chassis -- dial at 1500 Kcs.
 - Adjust I.F. Trimmer C9S and C9P on I.F. Transformer T2 for maximum output; then adjust Trimmer C8S and C8P on I.F. T1 for maximum output, using setting giving least regeneration and best tone quality.
 - Adjust Signal Generator to 1500 Kc., Dial to 1500 Kc and adjust Trimmer C4 on V. Capacitor to bring Oscillator to 1500 Kcs.
 - Adjust Trimmer C3 to maximum signal with Signal Generator disconnected from Ant. Terminal by about 4 inches or on a station signal near 1500 Kc. (~20 Kc.).
- Note: Above adjustments must be made with Base Plate on bottom of chassis.