

NOTE: To compensate for oscillator drift, a 10 mmfd. 5% ceramic disc temp. comp. capacitor (N-750) has been added in the oscillator circuit on later production.

SPARTON 5F1, 5F2

L.F. 455 KC.

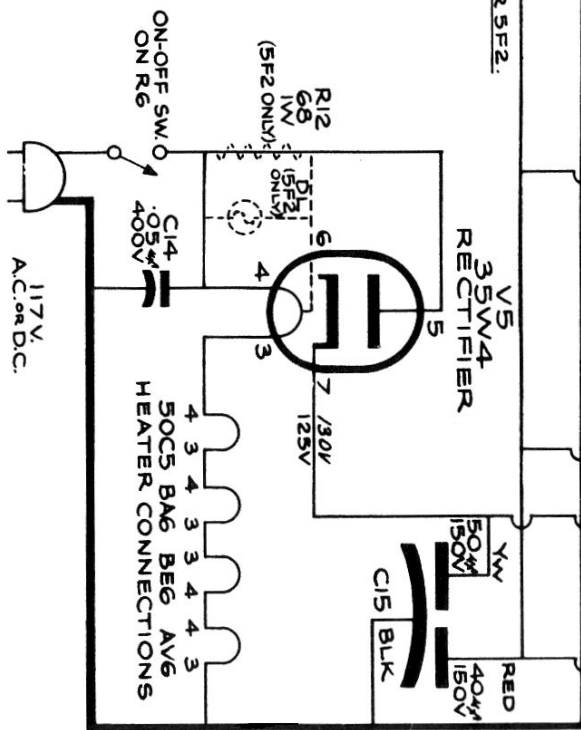

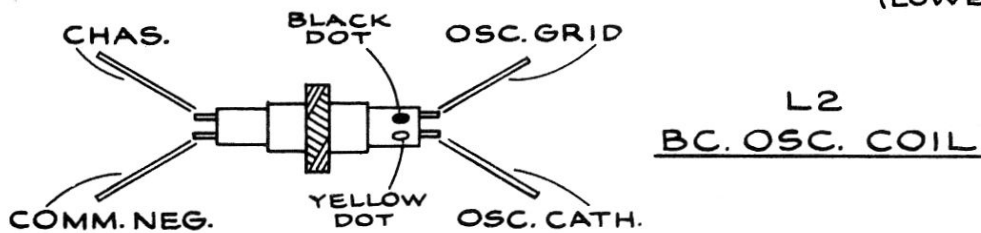
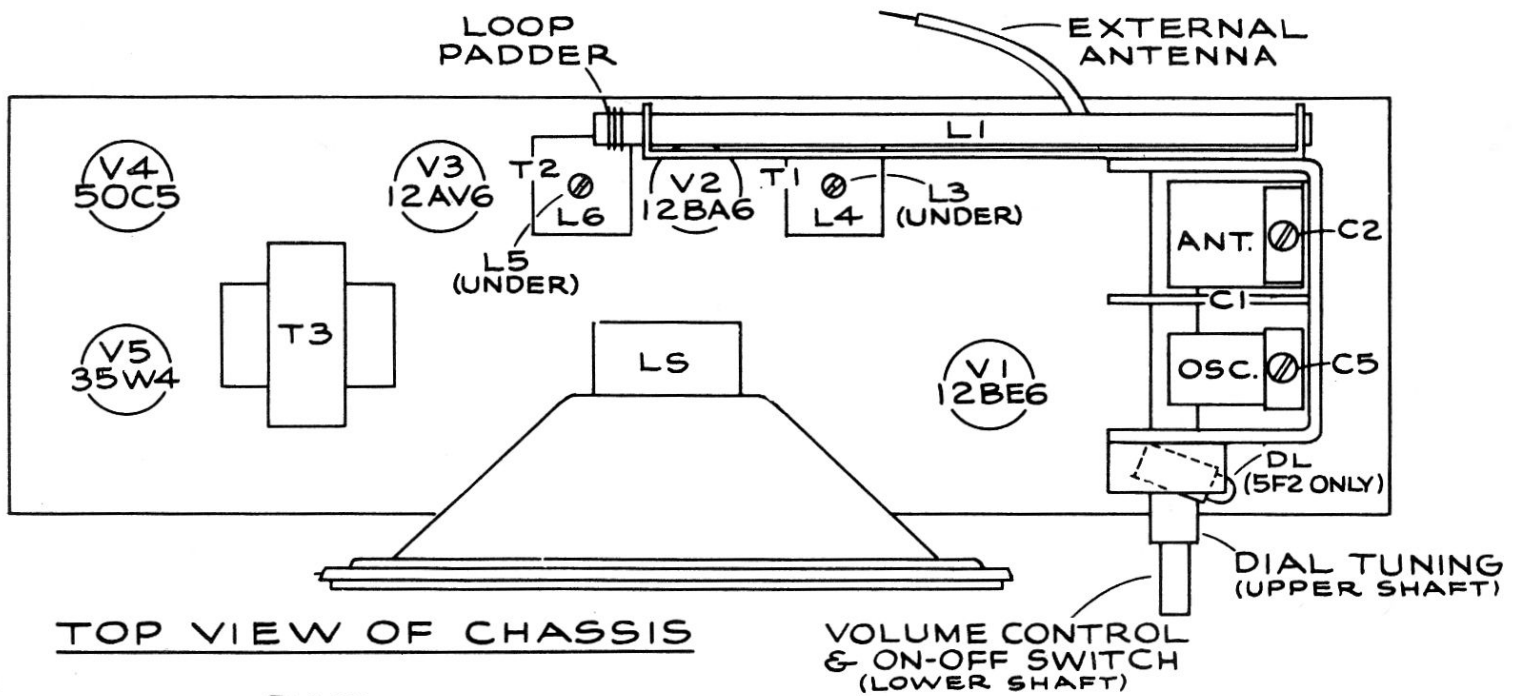

ELECTRICAL ALIGNMENT

At least 15 minute warm up period should be allowed before adjustments are made and base plate should be on chassis.

- Adjust signal Generator to 455 kcs. and connect to Antenna lead (white wire).
- Set Dial to 1500 kcs. and adjust I. F. iron cores with hexagon trimmer stick; starting with T2 adjust L6 then L5, next adjust L4 then L3 of T1.
- With Signal Generator and Dial set at 1500 kcs. adjust trimmer C5 to set oscillator and trimmer C2 for maximum output.

LOOP PADDER

Adjusted for optimum loop performance at the factory. Field adjustment usually is unnecessary.

- With Signal Generator and Dial set at 600 kcs. adjust loop padder for maximum output.
- Reset Signal Generator and Dial to 1500 kcs. readjust C5 and rock the tuning capacitor while adjusting C2 for maximum output.