

Sparton 5249

RCC - Sparton Data Sheet 112 - 1947-48

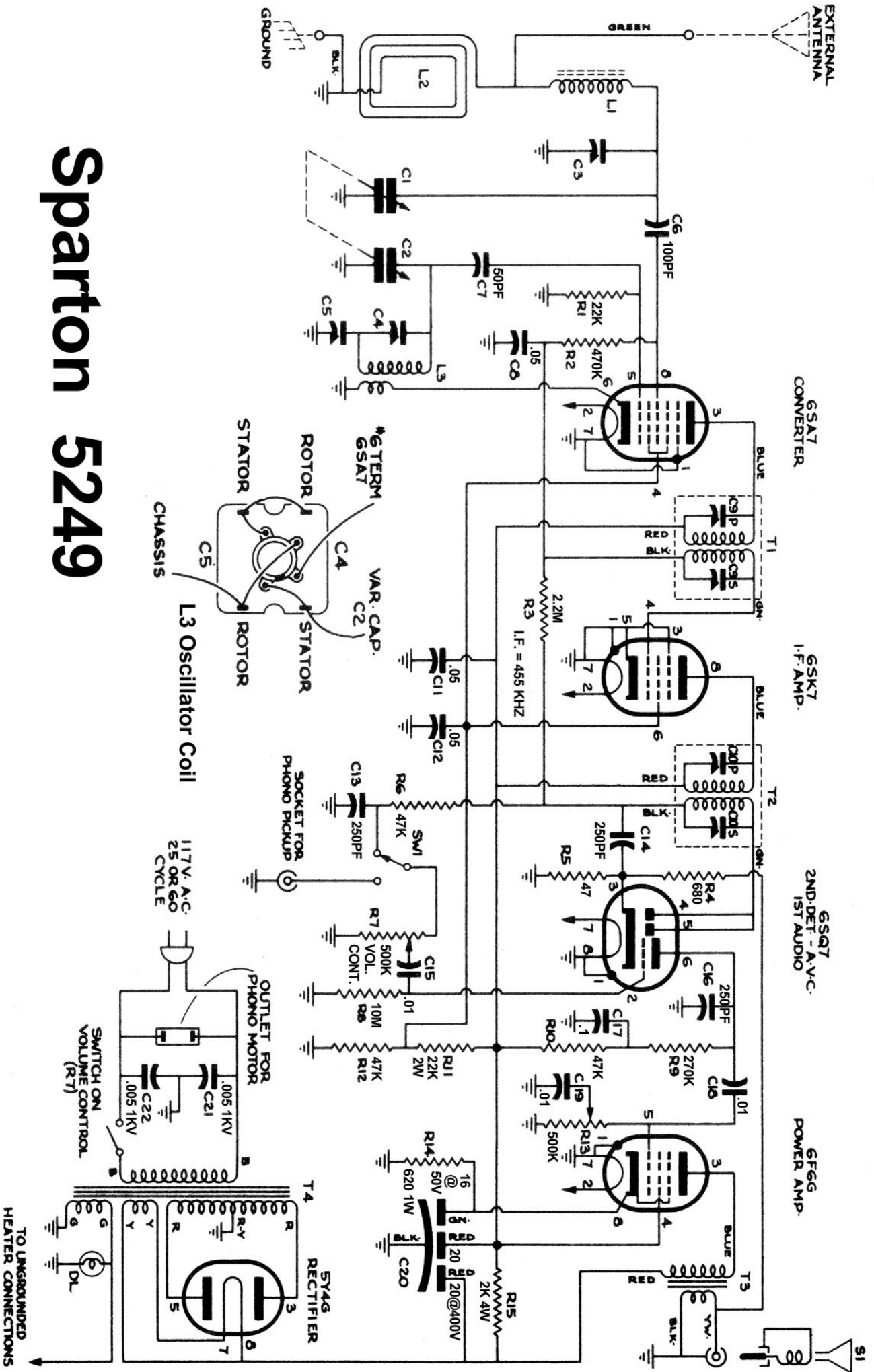

TO UNGROUNDING HEATER CONNECTIONS

Sparton 5249

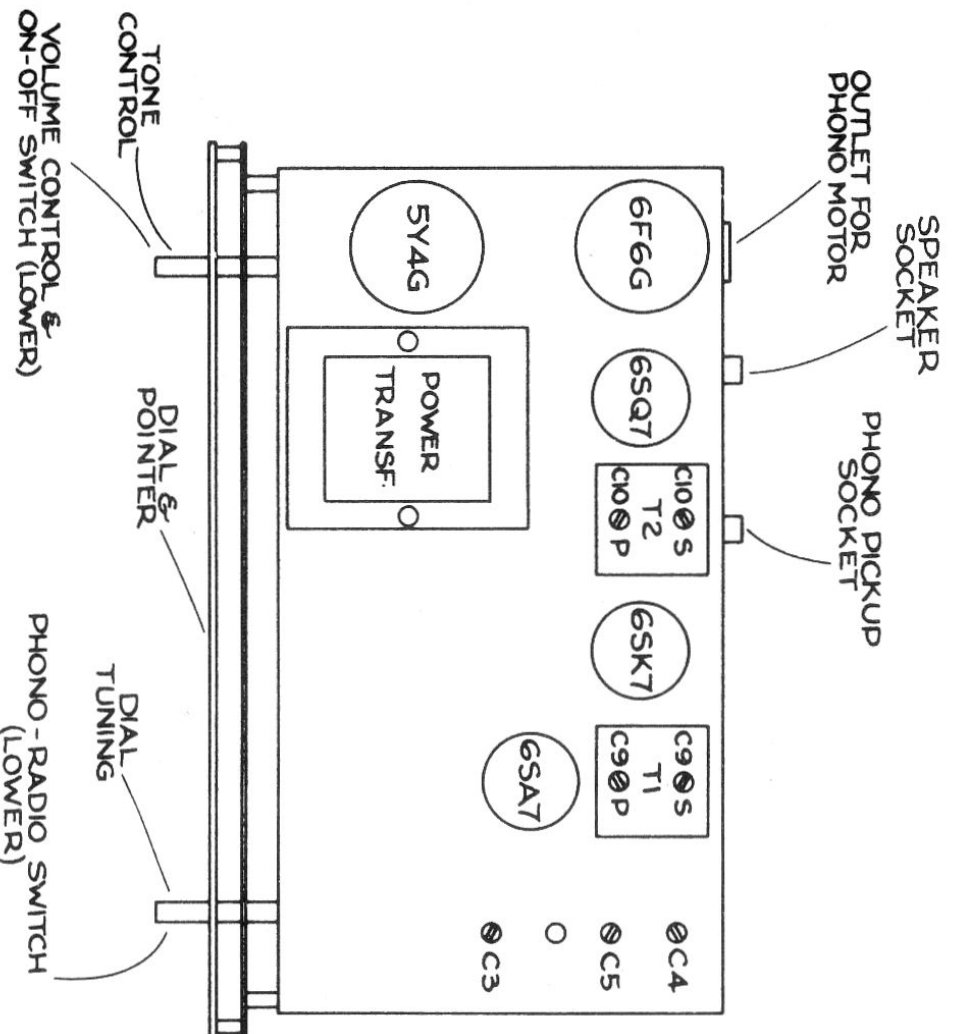

TOP VIEW OF CHASSIS

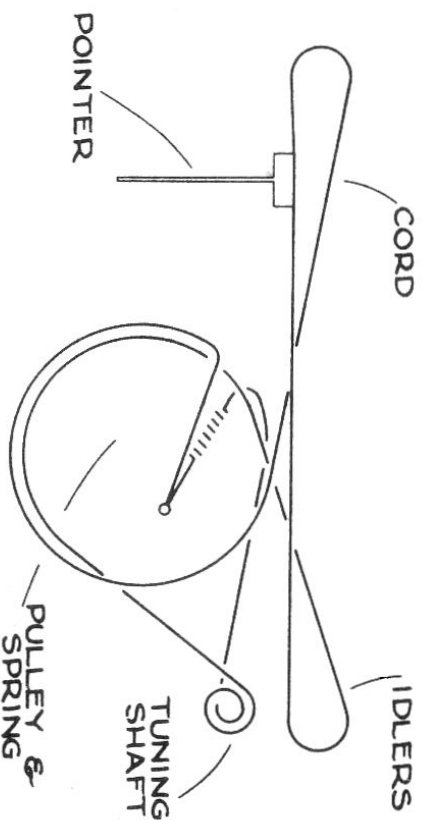

DIAL CORD ARRANGEMENT (VARIABLE CAPACITOR CLOSED)

Alignment

- Signal Generator at 455 Kcs. connected to Ant. and Gnd. post on rear of loop Antenna. Dial at 1500 Kcs, B/C Band.
- Adjust I.F. trimmers C10P, C10S, C9P, C9S, for maximum gain.
- Signal generator at 1500 Kcs, dial at 1500, adjust oscillator trimmer C4 to maximum signal, and antenna trimmer C3 for maximum output.
- Turn dial and Sig. Gen. to 600 Kc. and adjust C5 for maximum output, return to 1500 Kc and adjust C3 and C4 again for maximum.
- Above adjustments to be made with baseplate on chassis.