

Sparton 50153

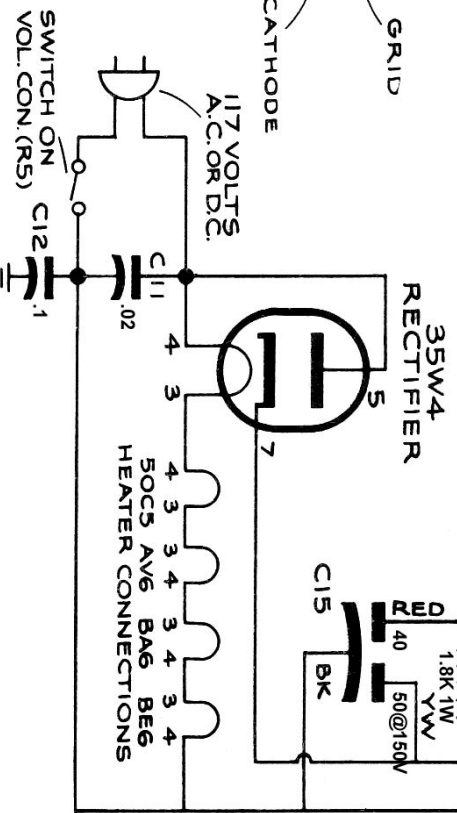
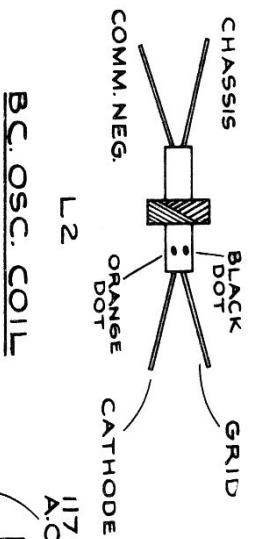

ELECTRICAL ALIGNMENT

At least 15 minute warm up period should be allowed before adjustments are made and base plate should be on chassis.

- Connect Signal Generator to Antenna terminal and adjust to 455 Kcs.
- Set Dial to 1500 Kcs. and adjust I.F. Iron cores with fibre trimmer stick; starting with T2 adjust L6 then L5, next adjust L4 then L3 of T1.
- With Signal Generator and Dial set at 1500 Kcs. adjust trimmer C3 to set oscillator and trimmer C2 for maximum output.

LOOP PADDER

Adjusted for optimum loop performance at the factory. Field adjustment usually is unnecessary.

- With Signal Generator and Dial set at 600 Kcs. adjust loop padder for maximum output.
- Reset Signal Generator and Dial to 1500 Kcs. readjust C3 and rock the tuning capacitor while adjusting C2 for maximum output.

Sparton 50153

