

Sparton 5009 AC/DC Receiver

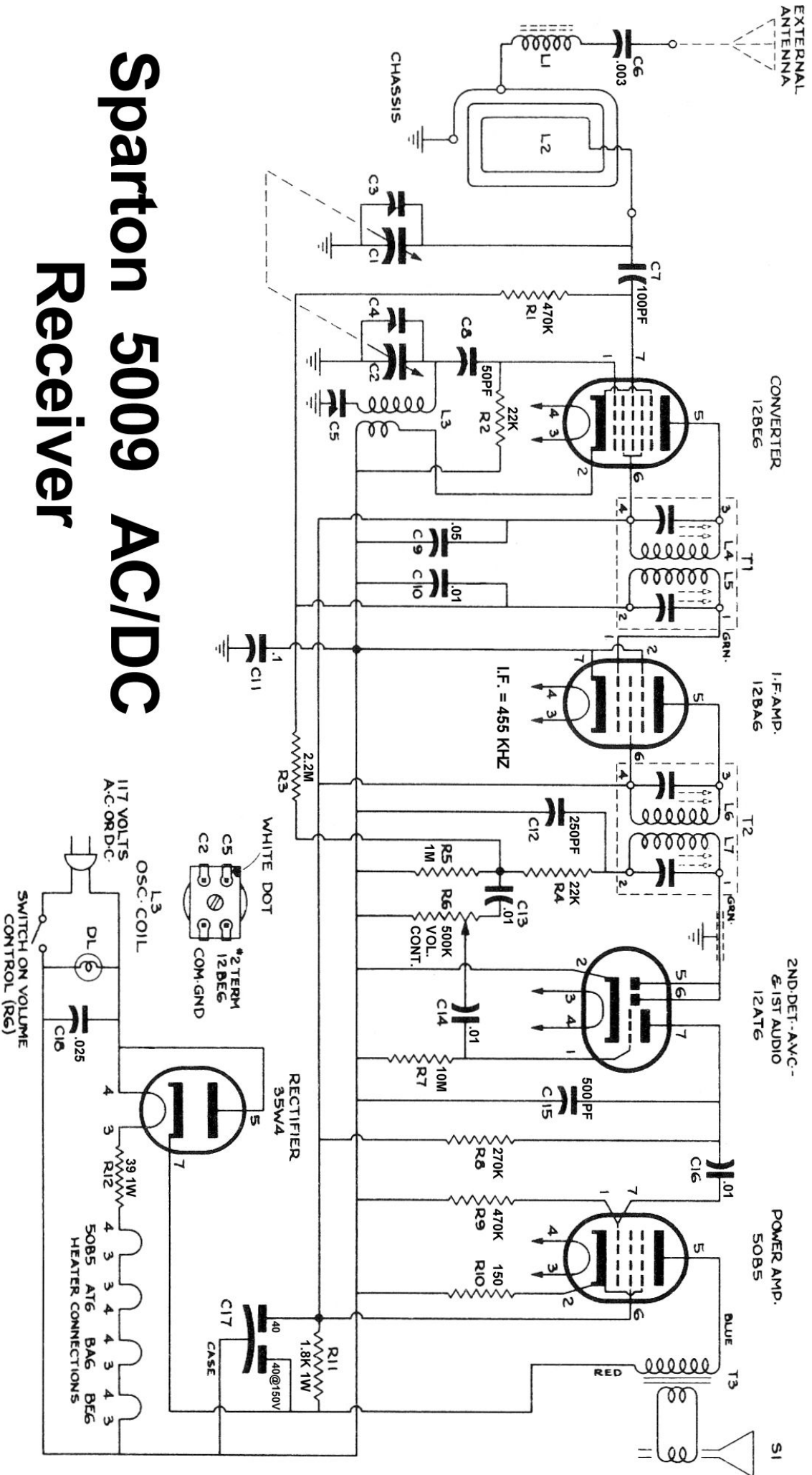

Sparton 5009 AC/DC Receiver

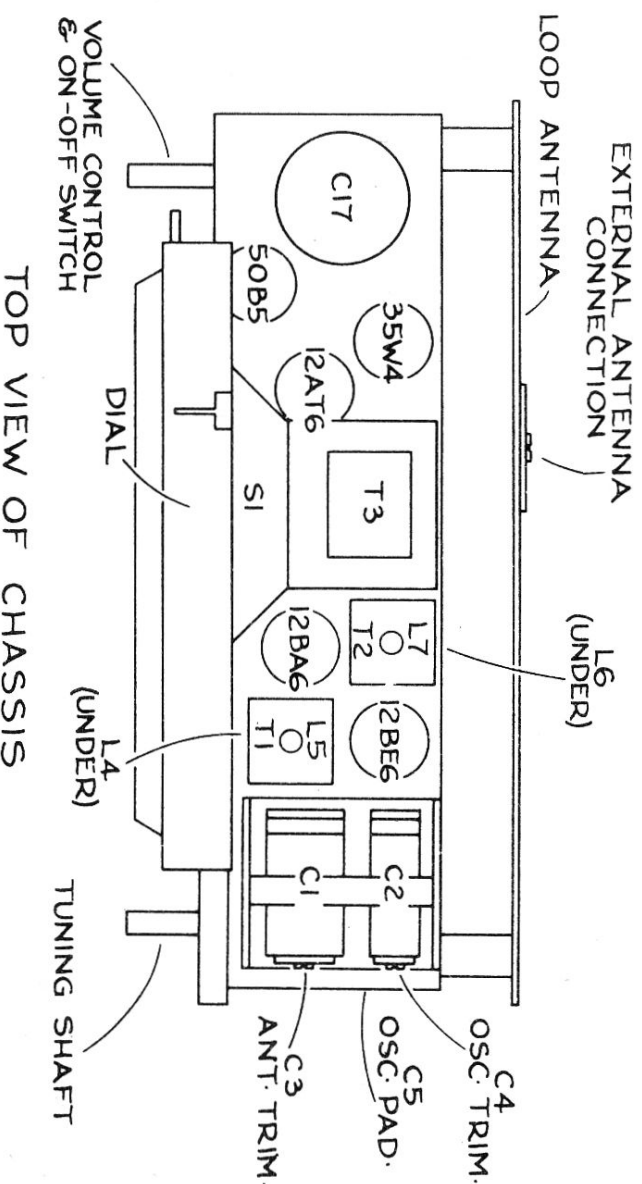
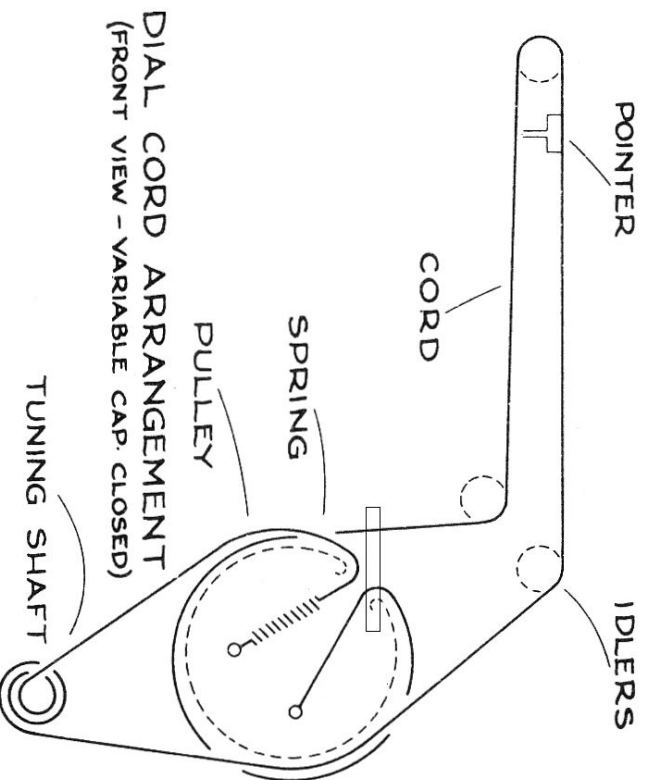

ALIGNMENT

- Adjust signal generator to 455 Kcs. and connect to Antenna terminal dial at 1500 Kcs.
- Adjust I.F. trimmer slugs (iron cores) through holes in top and bottom of #2 I.F. (T2) L7 and L6, then #1 I.F. (T1) L5 and L4. A trimmer stick with a fibre screw driver tip (insulated) is preferred.
- Signal generator at 1500 Kc, dial at 1500, adjust trimmer C4 to set oscillator on frequency, and trimmer C3 for maximum signal.
- Signal generator at 600 Kc adjust C5 for maximum signal with dial at 600 Kc or maximum signal nearest 600 Kc.
- Note: Base plate on chassis.