

SCHEMATIC DIAGRAM

MODEL 265

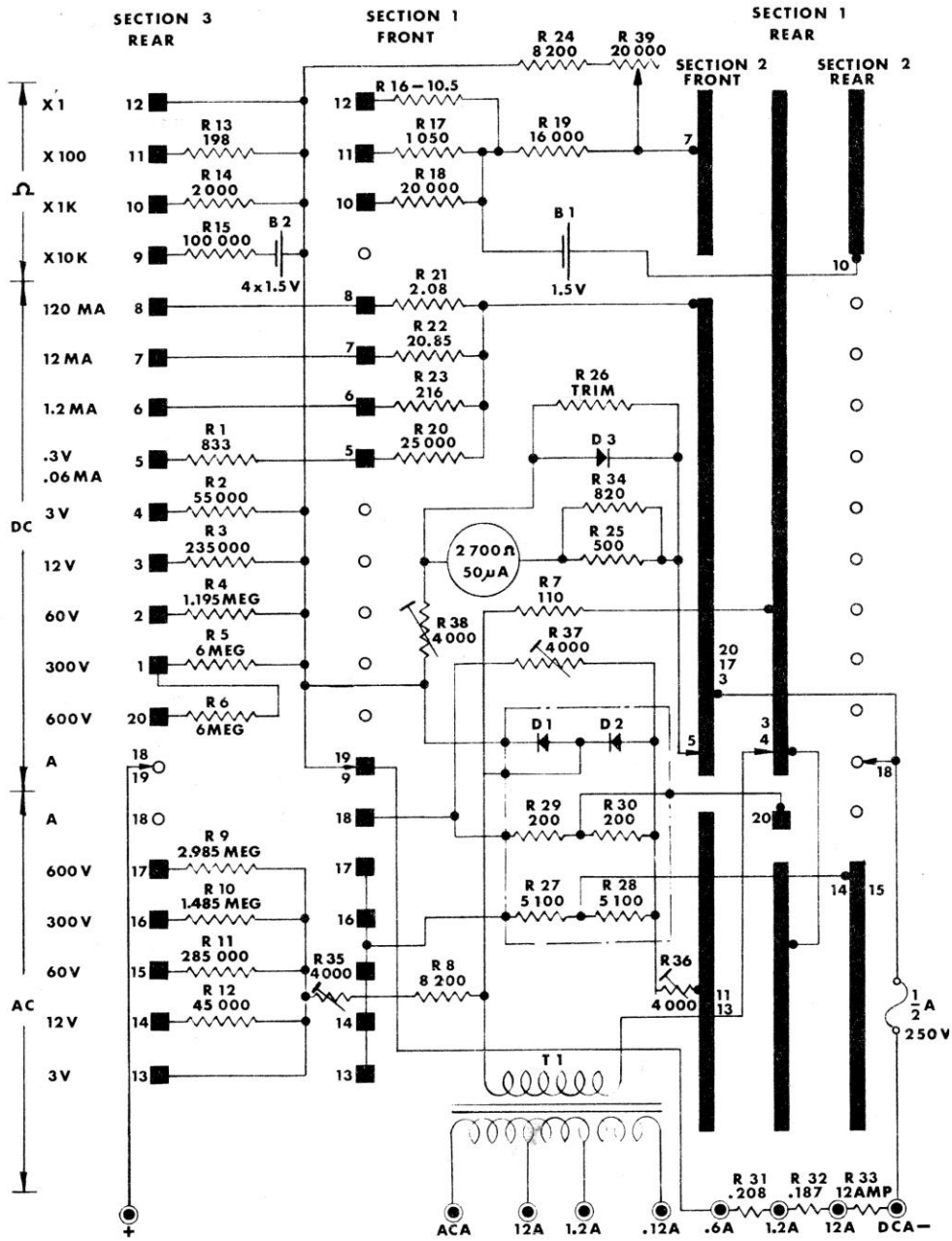

Figure 6-1. Schematic Diagram