

Item #	Part #	CONDENSERS
Variable	18565	450 mf. Gang
C1	18565	450 mf. Gang
C2	18565	450 mf. Gang
C3	18565	450 mf. Gang
Variable Micro		
C4	On Gang	Int. P. Pad.
C5	On Gang	Int. P. Pad.
C6	4671	0.05 mf. 200 V.
C7	4671	0.05 mf. 200 V.
C8	4671	0.05 mf. 200 V.
C9	4671	0.05 mf. 200 V.
C10	4671	0.05 mf. 200 V.
C11	4671	0.05 mf. 200 V.

Item #	Part #	CONDENSERS
Variable	18565	450 mf. Gang
C1	18565	450 mf. Gang
C2	18565	450 mf. Gang
C3	18565	450 mf. Gang
Variable Micro		
C4	On Gang	Int. P. Pad.
C5	On Gang	Int. P. Pad.
C6	4671	0.05 mf. 200 V.
C7	4671	0.05 mf. 200 V.
C8	4671	0.05 mf. 200 V.
C9	4671	0.05 mf. 200 V.
C10	4671	0.05 mf. 200 V.
C11	4671	0.05 mf. 200 V.

Item #	Part #	CONDENSERS
Variable	18565	450 mf. Gang
C1	18565	450 mf. Gang
C2	18565	450 mf. Gang
C3	18565	450 mf. Gang
Variable Micro		
C4	On Gang	Int. P. Pad.
C5	On Gang	Int. P. Pad.
C6	4671	0.05 mf. 200 V.
C7	4671	0.05 mf. 200 V.
C8	4671	0.05 mf. 200 V.
C9	4671	0.05 mf. 200 V.
C10	4671	0.05 mf. 200 V.
C11	4671	0.05 mf. 200 V.

Rogers 11-25 Console

11-15 Mantel

(Chassis Type 6R551)

Model "1-25" Console Model "1-15" Mantel TYPE 6R551 CHASSIS

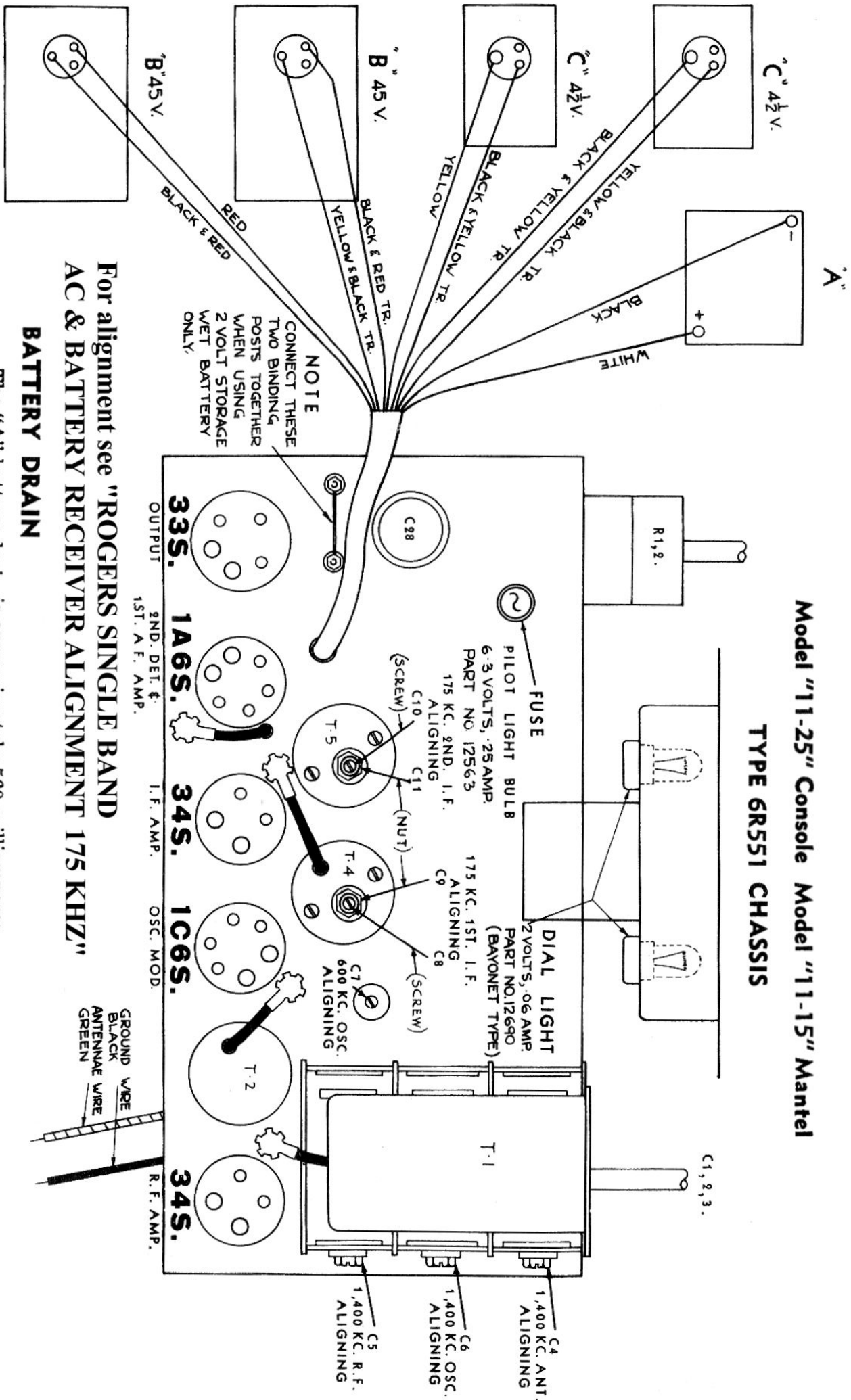

**For alignment see "ROGERS SINGLE BAND
AC & BATTERY RECEIVER ALIGNMENT 175 KHZ"**

BATTERY DRAIN

The "A" battery drain is approximately 560 milliamperes
680 milliamperes with the dial light operating.
The "B" battery drain is approximately 20 milliamperes
at 90 volts.