

G'ND. ANT. 1C6 1A4 1A4 30 6L5G 41

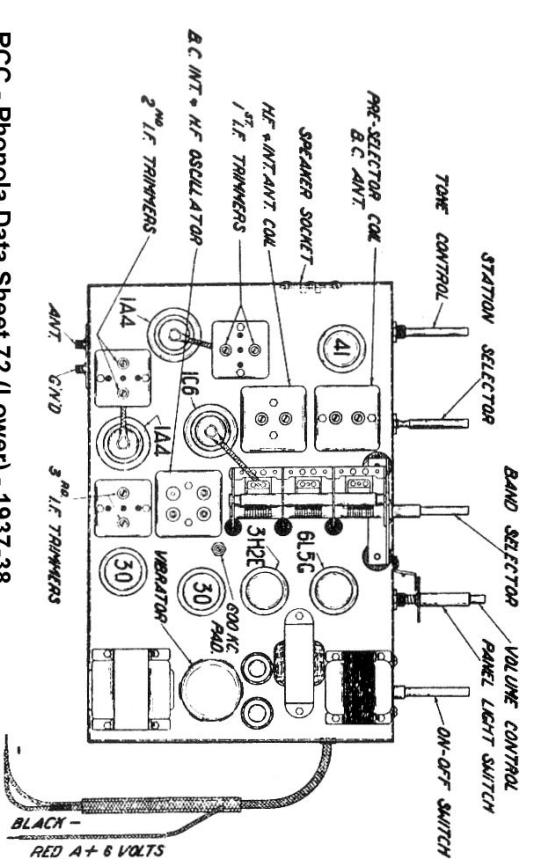
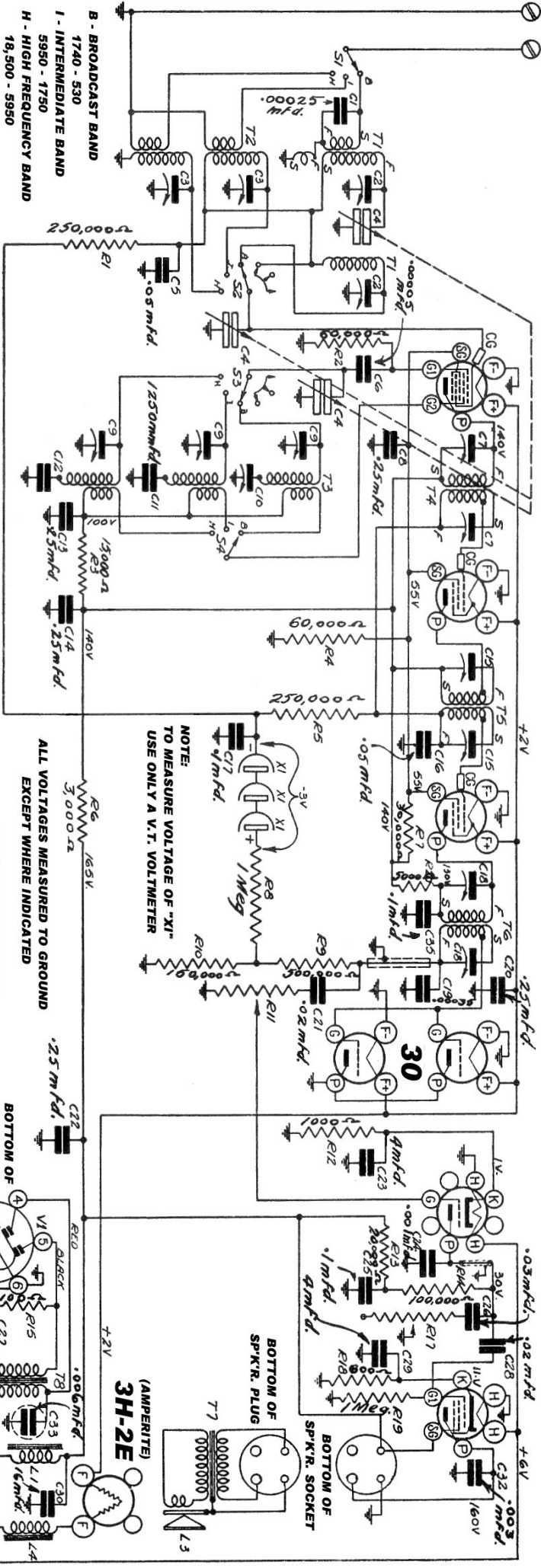

# Phonola - Electrohome Series 7V83-S

## I. F. ALIGNMENT

Set the signal generator to 456 K.C., and connect the output to the grid cap of the 1C6 tube through a .1 Mfd. condenser. The generator ground is connected to the chassis which must be externally grounded. The receiver dial is set to its highest frequency (gang open) the selector switch turned to broadcast position, and the volume control turned full on.

The I. F. trimmers, located as shown on the tube layout chart, are then adjusted by means of a non-metallic screw driver until maximum output results.

## R. F. ALIGNMENT

### Broadcast Band

1500 K. C. Set the signal generator to 1500 K.C., and connect its output lead to the antenna post of the receiver in series with a .00025 Mfd. condenser. The ground from the signal generator must be connected to the chassis, and externally grounded. With the band selector switch in the broadcast position, the dial of the receiver set at 1500 K.C. and the volume control turned full on, adjust the oscillator trimming condenser, located as shown on the tube layout chart, until a signal is heard.

**Note:** There may be two signals present, use the one obtained by the minimum capacity setting of the trimming condenser and adjust it to its peak. Then adjust the broadcast antenna and pre-selector trimming condensers for maximum output.

600 K.C. Set the receiver dial and the signal generator to 600 K.C. Adjust the 600 K.C. padding condenser for maximum output. While making this adjustment rock the tuning control back and forth through the signal until maximum output results.

Following this, it is advisable to repeat the procedure outlined for 1500 K.C. to compensate for any slight discrepancy caused by the adjustment of the series padding condenser.

RCC - Phonola Data Sheet 70 (Center) - 1937-38

# Electrohome 7V83-S Vibrator Type Radio

### Intermediate Band

5 M. C. Set the signal generator to 5 M.C. and connect its output to the antenna post of the receiver, through a 400 ohm resistor. The ground of the signal generator is connected to the chassis and externally grounded. Turn the band selector switch to the intermediate band, the receiver dial to 5 M.C., and the volume control full on. Adjust the intermediate oscillator trimming condenser, shown on the tube layout chart, until a signal is heard.

**Note:** There may be two signals present, use the one obtained by the minimum capacity setting of the trimming condenser and adjust it to its peak. Then adjust the intermediate antenna trimming condenser for maximum output.

### Short Wave Band

15 M. C. The same procedure is employed as outlined for the intermediate band, only, of course, the oscillator and antenna trimming condensers are adjusted at 15 M. C.