

Phonola -

Electrohome 7B52-M & 7B52-D

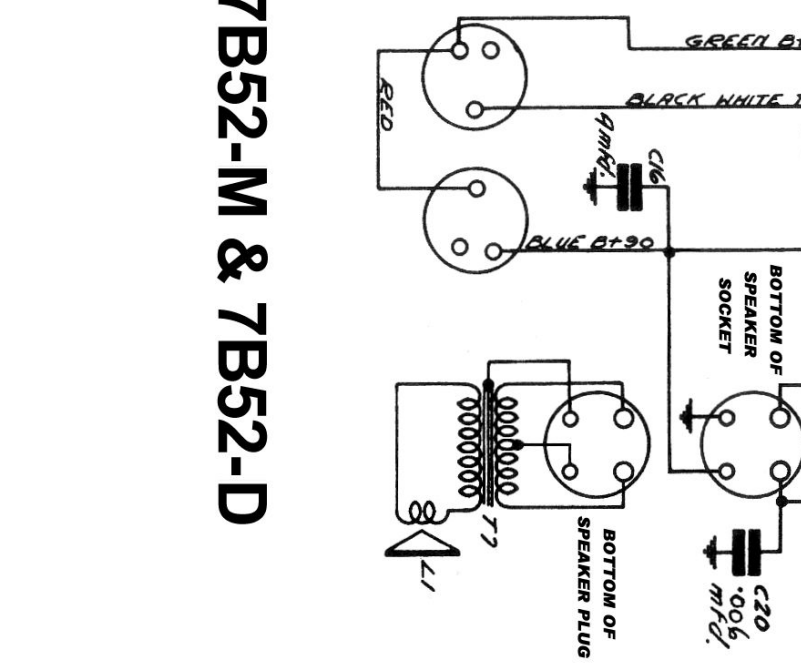

I. F. ALIGNMENT

Set the signal generator to 456 K.C., and connect the output to the grid cap of the 1C6 tube through a .1 Mfd. condenser. The generator ground is connected to the chassis ground lead or frame which must be externally grounded. The receiver dial is set to its highest frequency (gang open), the selector switch turned to broadcast band position, and the volume control turned full on.

The I. F. trimmers, located as shown on the tube layout chart, are then adjusted by means of a non-metallic screw driver until maximum output results.

Broadcast Band

R. F. ALIGNMENT

1500 K. C. Set the signal generator to 1500 K.C., and connect its output to the antenna lead of the receiver in series with a .00025 Mfd. condenser. The ground from the signal generator must be connected to the chassis ground lead or frame, and externally grounded. With the band selector switch in the broadcast position, the dial of the receiver set at 1500 K.C. and the volume control turned full on, adjust the broadcast oscillator trimming condenser (located as shown on the tube layout chart) until a signal is heard.

NOTE: There may be two signals present, use the one obtained by the minimum capacity setting of the trimming condenser and adjust it to its peak. (Then adjust the broadcast antenna trimming condenser for maximum output, on *Models 7B52-M and D, 7B62-E*).

600 K. C. Set the receiver dial and the signal generator to 600 K.C. Adjust the 600 K.C. padding condenser for maximum output. While making this adjustment rock the tuning control back and forth through the signal until maximum output results.

Following this, it is advisable to repeat the procedure outlined for 1500 K.C. to compensate for any slight discrepancy caused by the adjustment of the series padding condenser.

NOTE: There may be two signals present, use the one obtained by the minimum capacity setting of the trimming condenser and adjust it to its peak. The short wave antenna trimming condenser is then adjusted for maximum output.

Short Wave Band

15 M. C. Set the signal generator to 15 M.C. and connect its output to the antenna lead of the receiver, through a 400 ohm resistor. The ground of the signal generator is connected to the chassis frame or ground lead and must be externally grounded. Switch the receiver to short wave band, set the receiver dial to 15 M.C. and turn the volume control full on. Adjust the short wave oscillator trimming condenser (shown on the tube layout chart) until a signal is heard.

Electrohome

7B52-D

7B52-M

Battery Operated Radio Alignment Information