

Model 3118 1934-35 I.F. 260 Kc

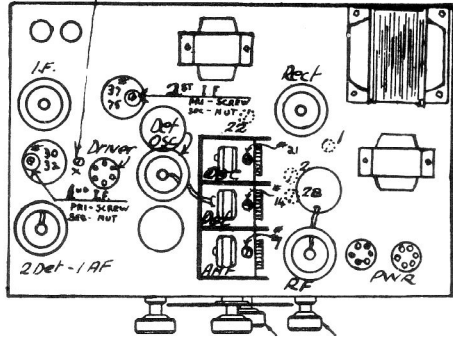

Model-30 1931-32

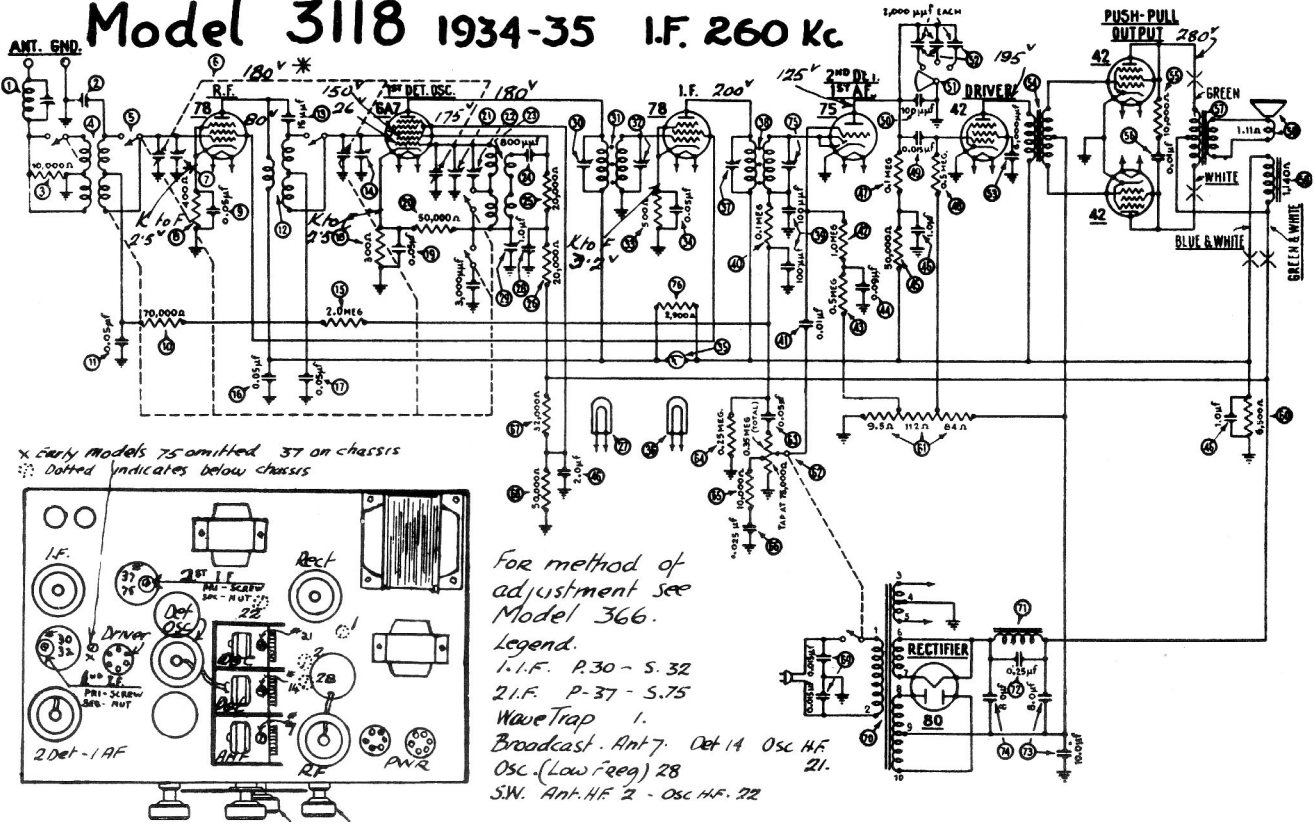