

Marconi Model

35

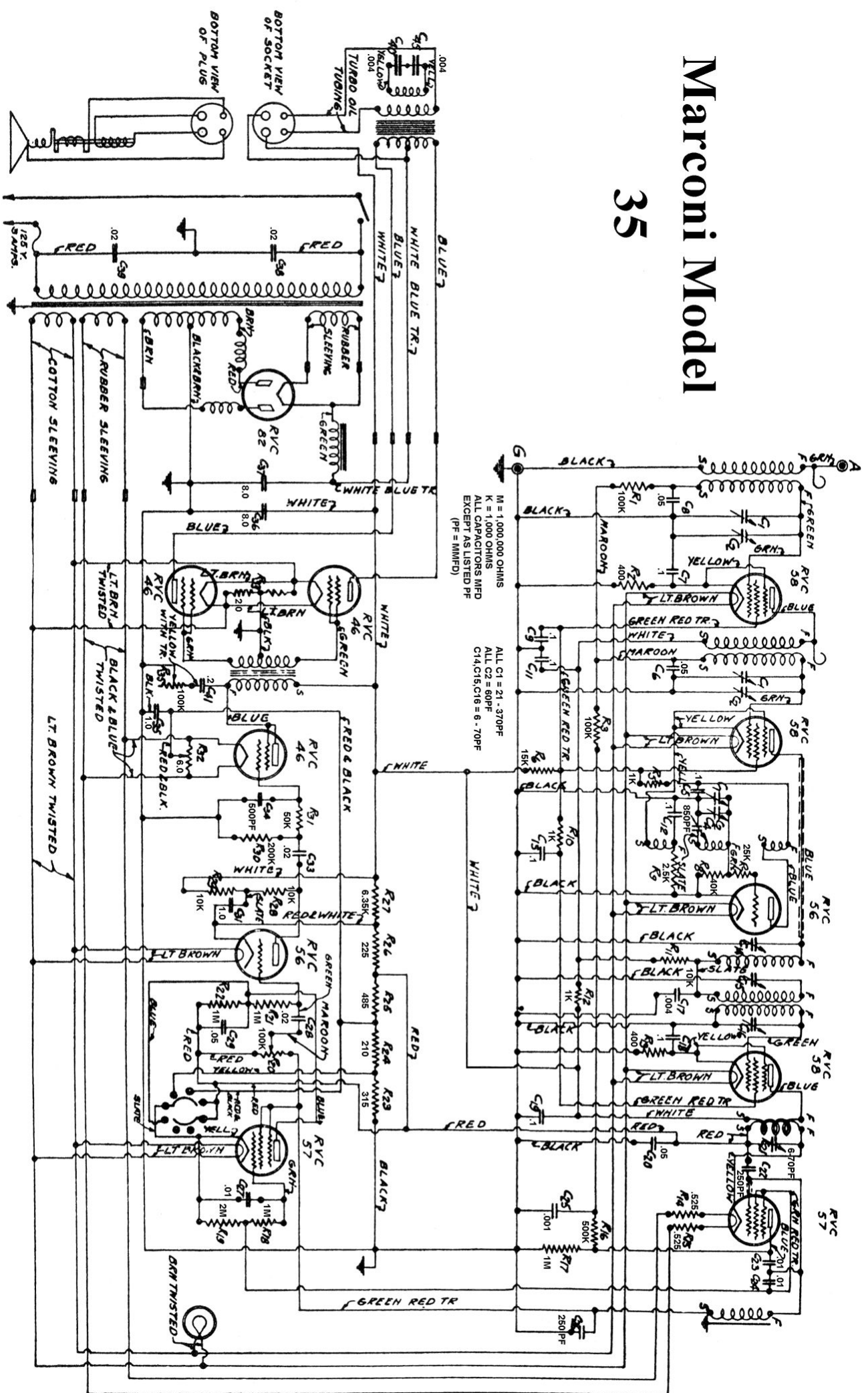

Marconi Model 35 Layout & Alignment, etc

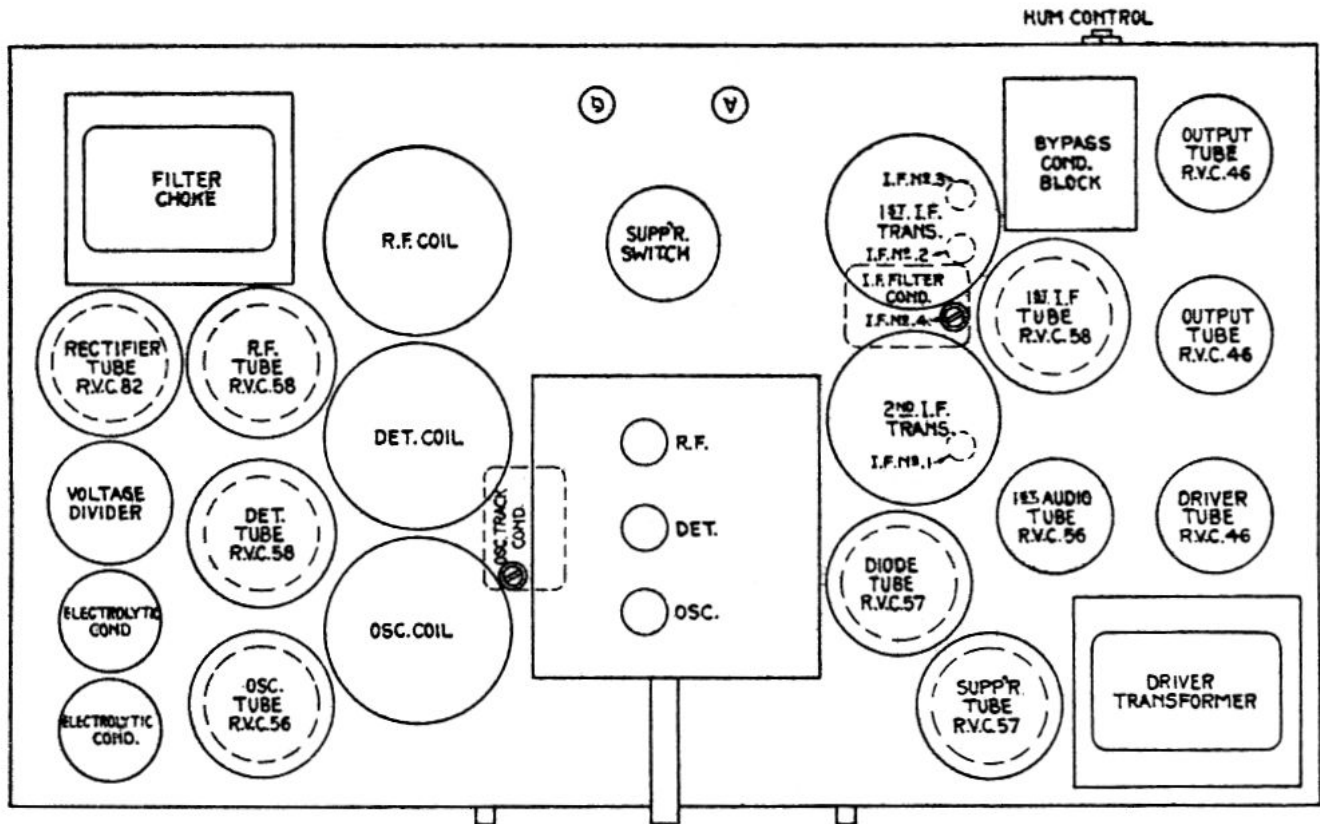

Model 35

TRIMMER ADJUSTMENTS—MODELS 35, 36-37

I.F.—175 K.C. Adjust in order—No. 1, No. 2, No. 3, No. 4.

R.F.—Trim at 1400 K.C. in order—Osc., Det., and R.F.

Oscillator Tracking Condenser—Adjust at 600 K.C.

VOLTAGE READINGS—MODELS 35, 36-37

	VOLTAGES to Cathode			VOLTAGES to Chassis			VOLTAGES to Cathode or Fil.				
	Grid	Pl.	Scr.	Sup.	Cath.	Htr.	Grid	Pl.	Scr.	Sup.	
B.C.-R.F.	0	215	90	0	*S/W R.F.	.5	230	30	0
1st Det.	0	185	85	0	6	..	*S/W Osc.	25	165
B.C. Osc.	0	90	Driver	18	230	225	..
I.F.	0	230	90	0	3	..	Power	0	380	0	..
Diode	+13	-18	-18	-18	40	25	Rect.	..	420
Suppressor	0	9	9	9	15						
1st. A.F.	.1	130	44	.1					

*Models 36-37 only.