

↑ DENOTES CHASSIS

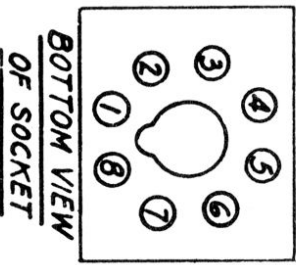

# Marconi Model 171

D 62232

D 62234

D 62239

D 62234

D 62234

D 62234

D 62234

D 62234

D 62234

D 62234

D 62234

D 62234

D 62234

# ALIGNMENT PROCEDURE MODELS 161, 171

BAND SW. SETTING	CONNECT S.G. OUTPUT TO	INPUT FREQUENCY	DIAL SETTING	DRUM IND.	ADJUST	CIRCUIT RESONATED	REMARKS
+BC	C.G. 6A8	462.5 KC			L9, L8, L7, L6	IF Input & Output	Max. Output
++BC BC BC	A & G	1600 KC	1600 KC	161.3	C5	BC Osc.	Adjust for Resonance Max. Output (Osc. Padder) Rock Gang
	A & G	1600 KC	1600 KC	161.3	C4	BC R.F.	
	A & G	580 KC	580 KC	19	L5	BC Osc.	
+++31M. 31M.	A & G	9.6 MC	9.6 MC	84	L3	31 M. Osc.	Adjust for Resonance Adjust for Max. Output
	A & G	9.6 MC	9.6 MC	84	C6	S.W. R.F.	
49M.	A & G	6 MC	6 MC	32.9	L4	49 M. Osc.	Adjust for Resonance
25M.	A & G	11.7 MC	11.7 MC	31.2	L2	25 M. Osc.	Adjust for Resonance
19M.	A & G	15.2 MC	15.2 MC	69.2	L1	19 M. Osc.	Adjust for Resonance

+ I.F. ALIGNMENT: Short osc. section of gang capacitor through 0.1 Mfd. For oscillograph alignment, connect oscillograph input across R-9. Adjust for overlapping double image of maximum amplitude.  
 ++ Before proceeding with R.F. Alignment, see that dial pointer is set over last graduation mark at low frequency and (Gang to be at maximum capacity).  
 +++Note 31 Metre Band must be aligned before any of the other short-wave bands.

If the chassis is realigned in the cabinet, the above dial settings may be followed. If, however, the chassis is removed, the dial scale is left attached to the cabinet. In order to guide servicemen working under the latter circumstances, a scale calibrated in 180 degrees has been attached to the back of the dial drum. A pointer should be improvised from a piece of stiff wire and with the gang capacitor set at maximum capacity (plates fully meshed) the improvised pointer should be set to 0 degrees. The Drum Indicator readings shown in the alignment chart can then be followed. After chassis has been realigned and installed in cabinet set Dial Pointer to last calibration mark on low frequency end with gang capacitor at maximum and clip same to drive cord.

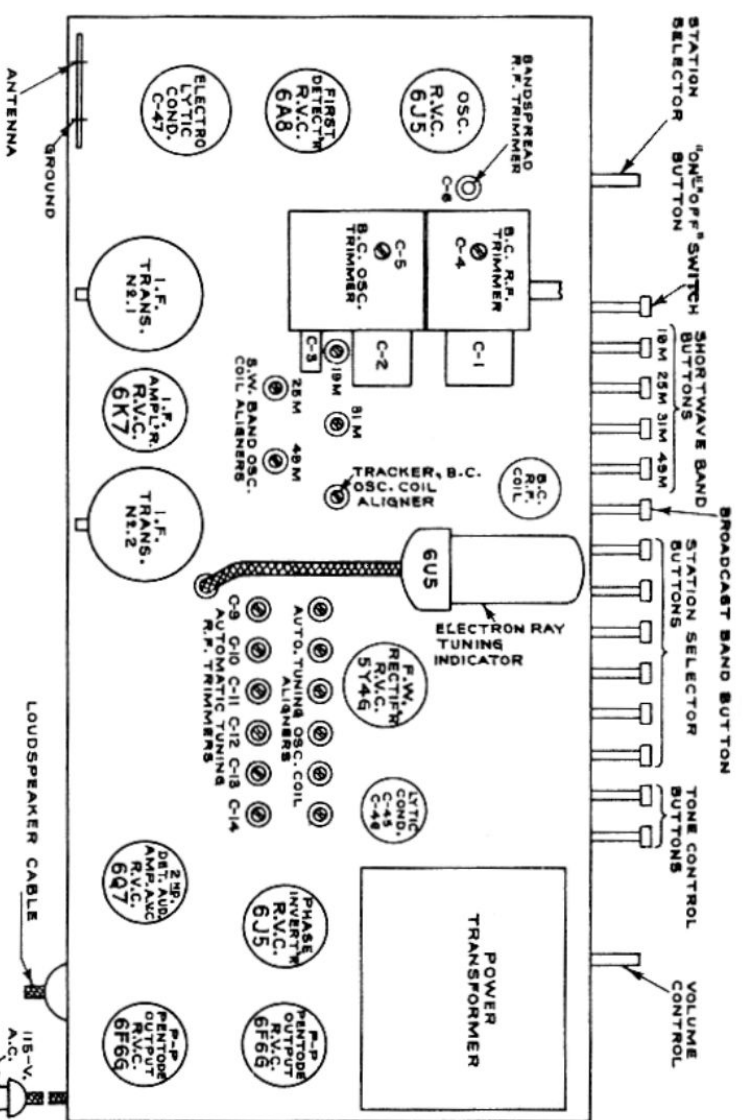

## Marconi Models 161 - 171