

CIRCUIT DESCRIPTION

The Model HN-31 "Antenna" Dummy RF Load was designed as a small convenient package capable of handling a kilowatt of power. (See Figure 1). The oil-cooled, temperature-stable resistive element provides a very low VSWR (voltage standing wave ratio) up to 400 megacycles. A special circuit is incorporated to provide a DC voltage for monitoring relative output power.

Refer to the Schematic Diagram below for a better understanding of the following description.

When power is applied to the circuit, R1, the 50

Ω resistor element (dummy load), absorbs this power and converts it into heat. The heat is dissipated into and stabilized by the oil bath which envelops the resistor element.

The output circuit, used for monitoring, is isolated from the 50 Ω resistor element (input circuit) by R2. This relatively high impedance separation allows only a portion of the input voltage to pass to R3 of the output circuit. The voltage developed across R3 is presented to D1. (Keep in mind that this voltage is relative to the input RF power). Half-wave diode rectifier D1, combined with filter capacitor C1, presents a DC output voltage for monitoring purposes.

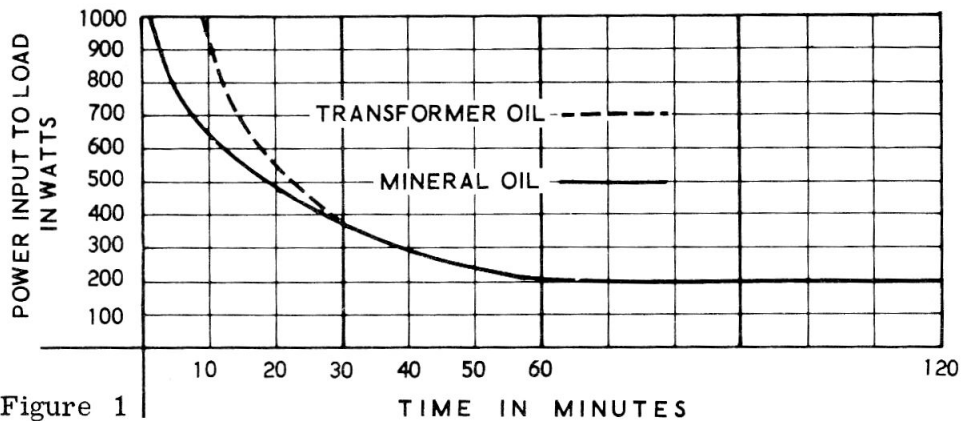
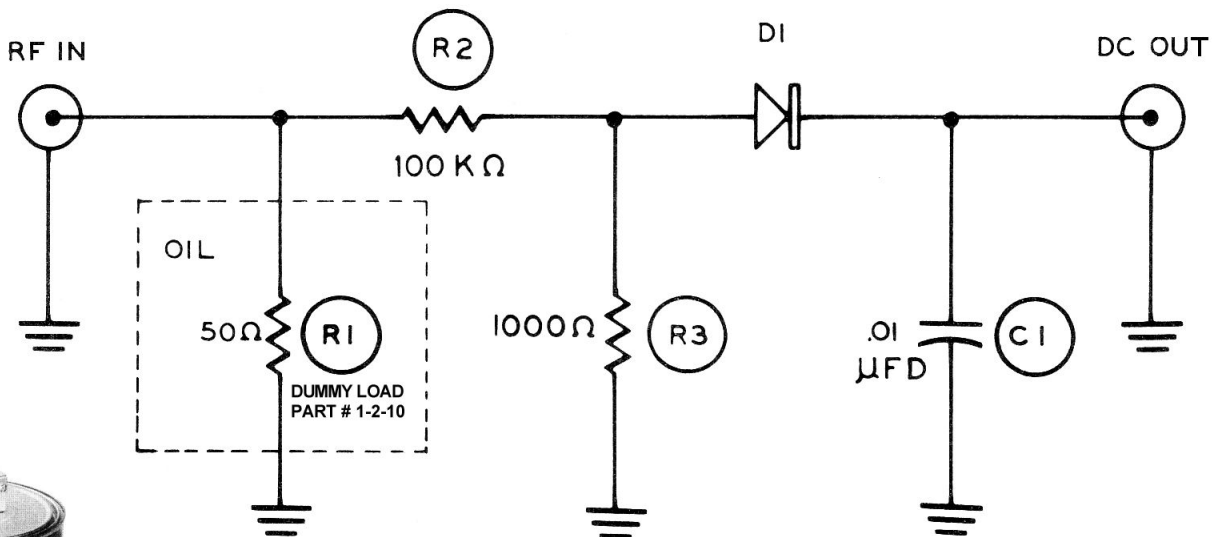

Figure 1



**SCHEMATIC OF THE
HEATHKIT®
"ANTENNA"
DUMMY RF LOAD
MODEL HN-31**

