

- NOTES:
- 1- FUNCTION SWITCH IN CCW POSITION (BROADCAST BAND).
 - 2- VOLTAGE TOLERANCE ± 20%.
 - 3- ALL VOLTAGES MEASURED WITH V.T.V.M. WITH FUNCTION SWITCH IN B.C POSITION.

Fleetwood 2053

ALIGNMENT DATA

Never attempt any adjustments on this receiver unless it becomes necessary to replace a coil or transformer, or unless the adjustments have been tampered with in the field. Always make certain that other circuit components, such as tubes, condensers, resistors, etc., are normal before proceeding with realignment.

If realignment is necessary follow the instructions given below in the order listed. After realignment has been completed repeat the procedure as a final check.

1. Connect output meter across voice coil (or V.T.V.M. from AVC line to chassis). Set function switch to broadcast position.
2. Connect signal generator through 100 MMFD condenser to pin No. 7 on 6BE6 socket (oscillator grid), apply 455 KC signal, modulated at 30%.
3. Adjust I.F. No. 2 and No. 1 adjusting screws for maximum output in the following order:
 - (a) I.F. No. 2 bottom
 - (b) I.F. No. 2 top
 - (c) I.F. No. 1 bottom
 - (d) I.F. No. 1 top
 repeat if necessary, keep signal at minimum.
4. Connect signal generator to Antenna terminal on loop.
5. Apply 530 KC signal, turn tuning condenser to fully closed position and adjust Broadcast Oscillator (L2) tuning slug for maximum output.
6. Apply 1620 KC signal, turn tuning condenser to fully open position and adjust Broadcast Oscillator trimmer (C2A) for maximum output.

7. Repeat 5 and 6.

8. Apply 1400 KC signal, tune set to that frequency and adjust Broadcast Antenna trimmer (C1A) for maximum output.

NOTES:

1. During entire alignment procedure, keep signal generator coupled as loosely as possible and keep generator output at minimum.

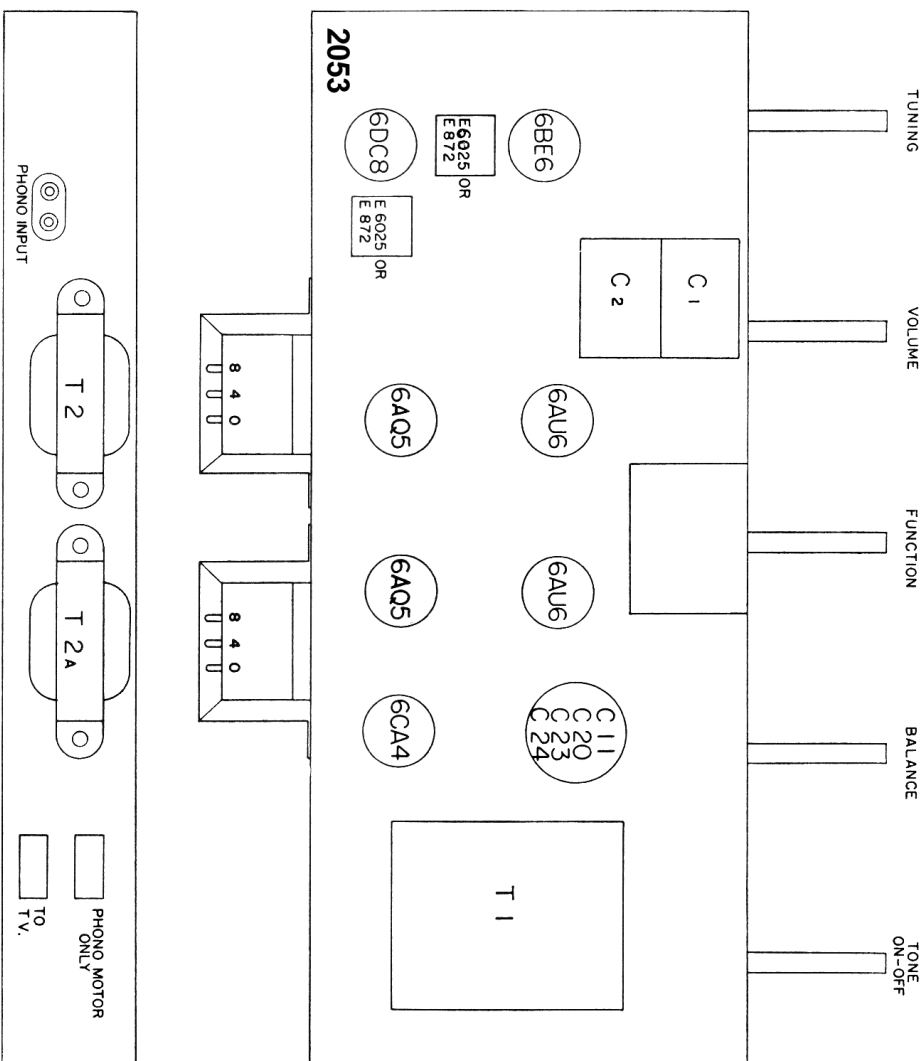

Fig. 2