

AM-FM TUNER SCHEMATIC - ROXBOROUGH

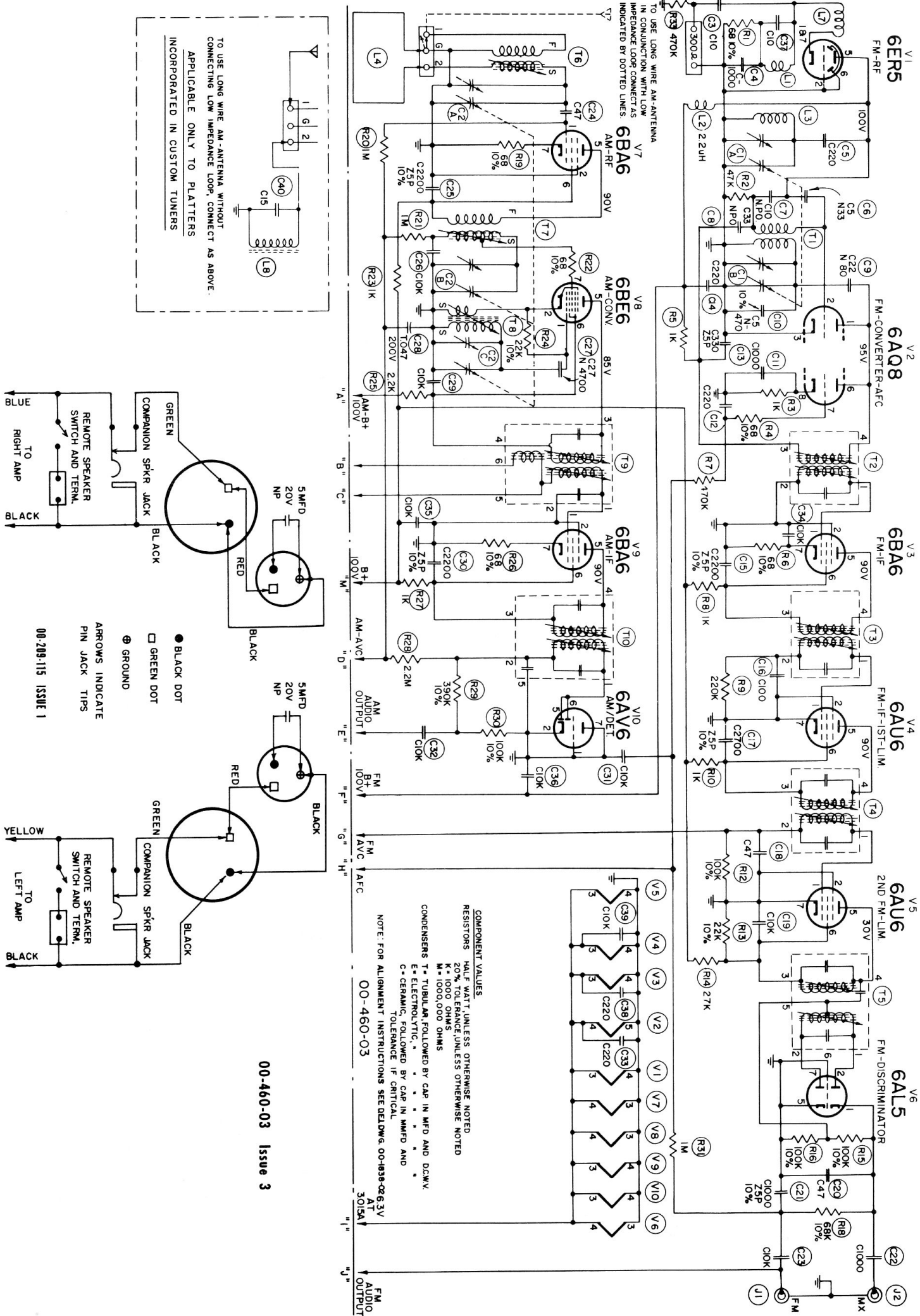

TO USE LONG WIRE AM-ANTENNA WITHOUT CONNECTING LOW IMPEDANCE LOOP, CONNECT AS ABOVE.
 APPLICABLE ONLY TO PLATTERS INCORPORATED IN CUSTOM TUNERS

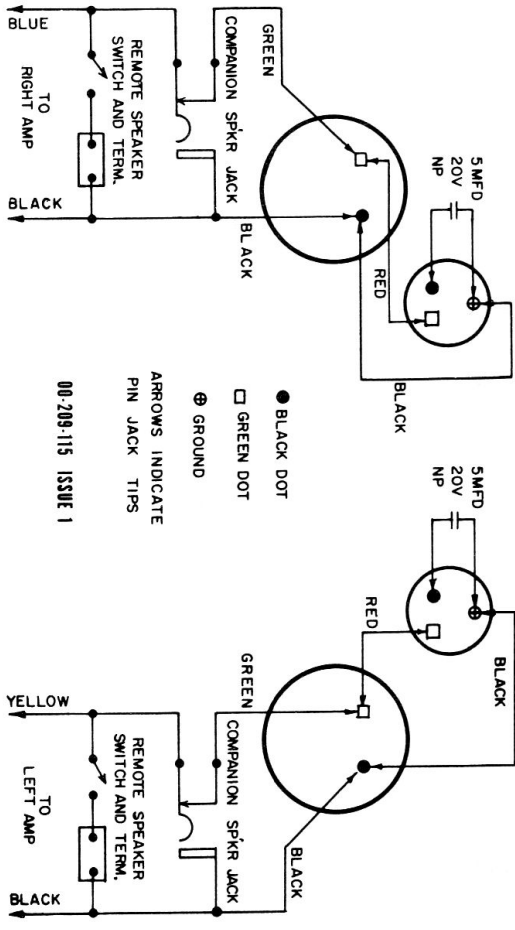

00-460-03 Issue 3

00-209-115 ISSUE 1

ALIGNMENT INSTRUCTIONS

STEP NO 3

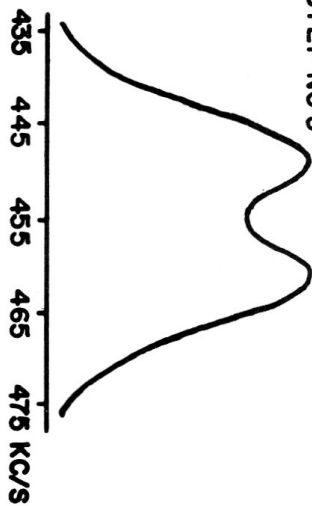

ELECTROHOME ROXBOROUGH

STEP	DUMMY ANTENNA	SIGNAL APPLIED TO	FREQ.	MODULATION	BAND SWITCH SETTING	DIAL POINTER SETTING	INDICATING METER	ADJUST	REMARKS	NOMINAL & SENSITIVITY
1	.05 uF	Pin No. 1 V9 6BA6	455 Kc/s	400 c.p.s. AM at 30%	AM	600 Kc/s	AC-VTVM To Point "E"	T10 2nd. AM-IF	Adjust for maximum output.	4000 uv for 20 mv output
2	.05 uF	Pin No. 7 V8 6BE6	455 Kc/s	400 c.p.s. AM at 30%	AM	600 Kc/s	AC-VTVM To Point "E"	T9 1st. AM-IF	Adjust for maximum output.	300 uv for 20 mv output
3	Change Band Switch to (AM Hi-F) Tune Signal Generator across 440-470 Kc/s Frequency Range and check for approx. response curve as shown. This test should preferably be made with a proper sweep generator and scope.									
4	200 uF	AM Ant. Strip No. 1	600 Kc/s	400 c.p.s. AM at 30%	AM	600 Kc/s	AC-VTVM To Point "E"	T6, T7 and T8	Connect for long wire antenna, adjust for maximum output.	2.5 mv for 20 mv output
5	200 uF	AM Ant. Strip No. 1	1460 Kc/s	400 c.p.s. AM at 30%	AM	1460 Kc/s	AC-VTVM To Point "E"	C2A, C2B and C2C Trimmers	Connect for long wire antenna, adjust for maximum output.	1.8 mv for 20 mv output
6	Repeat steps 3 and 4, check for band coverage at 535 Kc/s - 1650 Kc/s and for tracking at 950 Kc/s.									
7	-	Pin No. 1 V4 6AU6	10.7 Mc/s	-	FM	Point of no Interference	DC-VTVM To Point "G"	T4 3rd. FM-IF	Adjust for maximum meter deflection.	15000 uv for 1V output
8	-	Pin No. 1 V3 6BA6	10.7 Mc/s	-	FM	Point of no Interference	DC-VTVM To Point "G"	T3 2nd. FM-IF	Adjust for maximum meter deflection.	250 uv for 1V output
9	-	CIA FM Gang	10.7 Mc/s	-	FM	Point of no Interference	DC-VTVM To Point "G"	T2 1st. FM-IF	Adjust for maximum meter deflection.	
10	-	Pin No. 1 V4 6AU6	10.7 Mc/s	-	FM	Point of no Interference	DC-VTVM To Pin No. 5 of T5	T5 FM Discriminator Primary	Adjust for maximum meter deflection.	10000 uv for 3V output
11	-	Pin No. 1 V4 6AU6	10.7 Mc/s	-	FM AFC	Point of no Interference	DC-VTVM To Point "H"	T5 FM Discriminator Secondary	Adjust for zero voltage.	
12	270 ohms	FM Ant. Term. Strip	90 Mc/s	400 c.p.s. FM 22.5 Kc/s	FM	90 Mc/s	AC-VTVM To Point "J"	Expand or compress L3 and T1	Adjust for maximum output.	3 uv for 100 mv output
13	270 ohms	FM Ant. Term. Strip	106 Mc/s	400 c.p.s. FM 22.5 Kc/s	FM	106 Mc/s	AC-VTVM To Point "J"	C1B and CIA Trimmers	Adjust for maximum output.	2.5 uv for 100 mv output
14	Repeat steps 11 and 12 until output drops at least 20 db. when mod. is turned off. 3.5 uv									

NOTE: To achieve more accurate alignment of FM IF's and Discriminator it is preferable to use a proper sweep generator and oscilloscope.

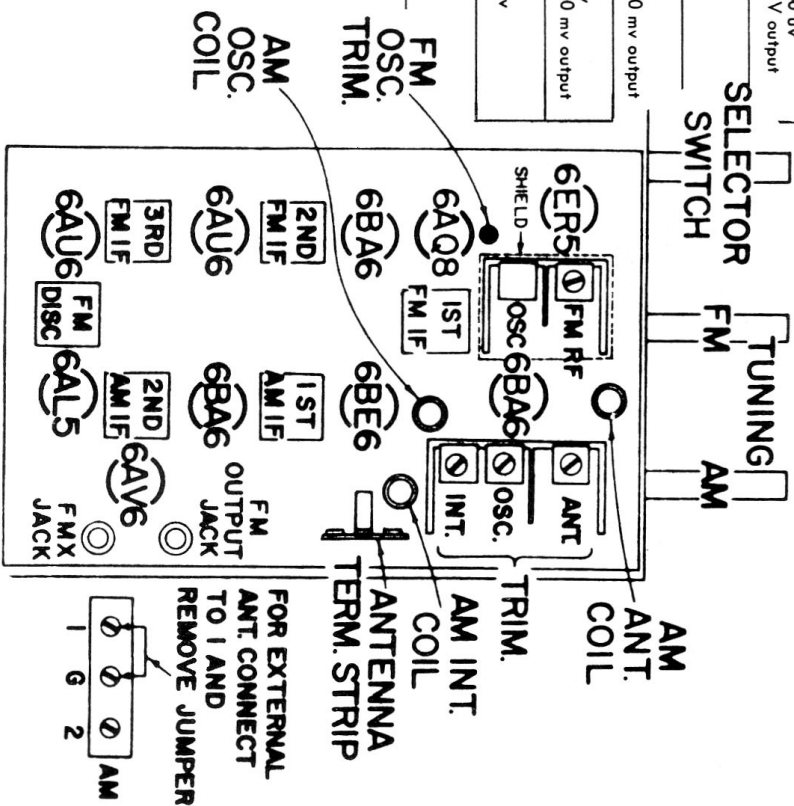
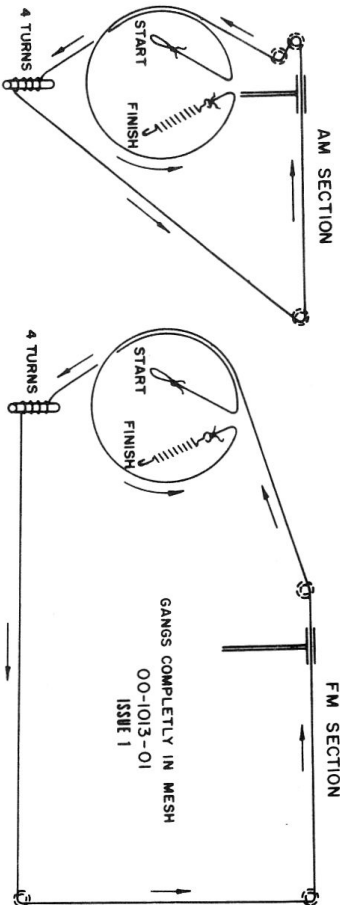

AM-FM AMPLIFIER SCHEMATIC - ROXBOROUGH

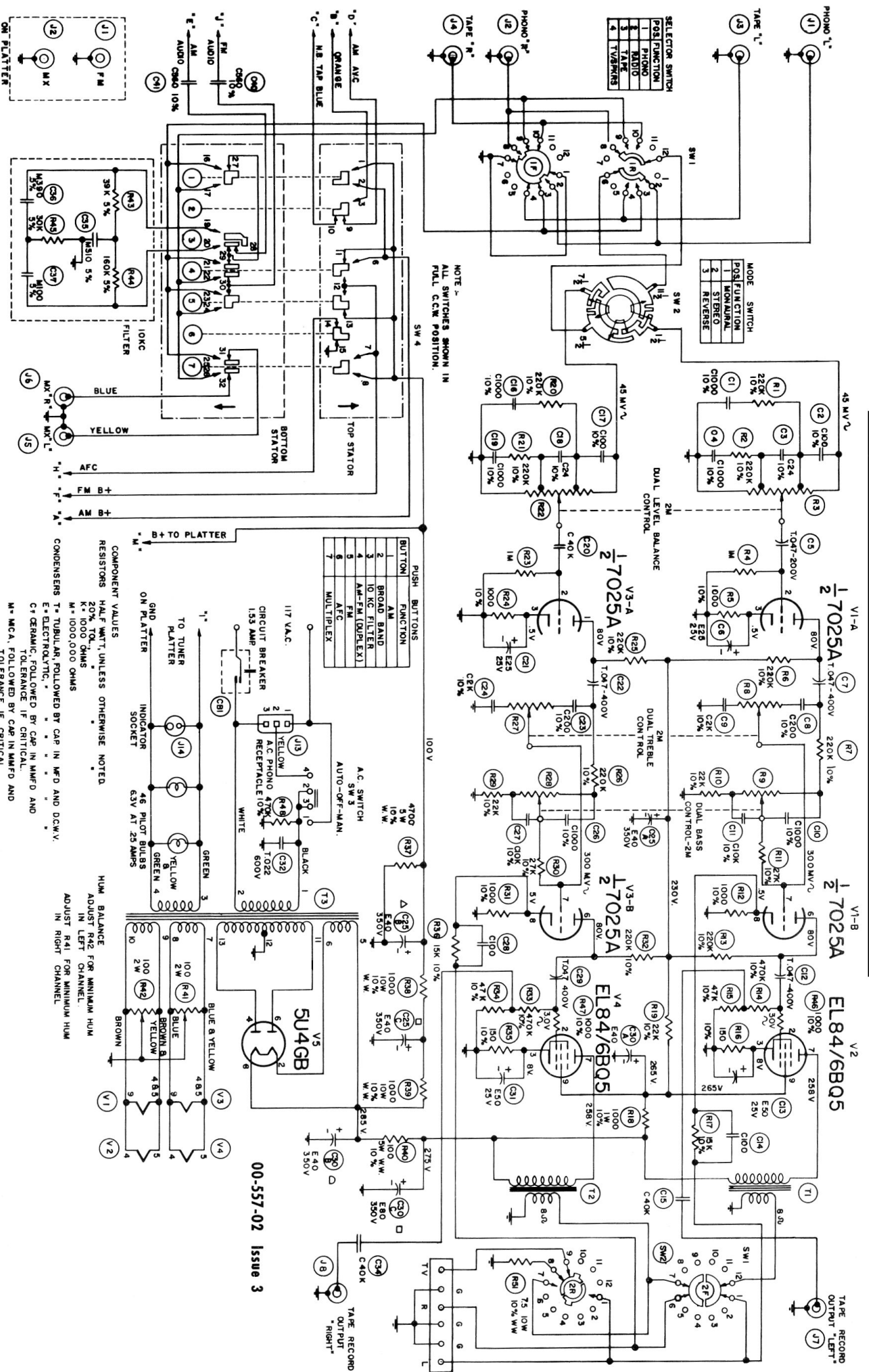

POSITION	FUNCTION
1	PHONO
2	TUNING
3	TAPE
4	TV/RADIO

MODE	FUNCTION
1	NORMAL
2	STEREO
3	REVERSE

PUSH BUTTONS	FUNCTION
1	AM
2	BROAD BAND
3	10 KC. FILTER
4	AM-FM (DUPLEX)
5	FM
6	AFC
7	MULTIPLEX

COMPONENT VALUES
 RESISTORS HALF WATT. UNLESS OTHERWISE NOTED.
 20% TOL.
 * 1000 OHMS
 M = 1000,000 OHMS
 CONDENSERS T = TUBULAR, FOLLOWED BY CAP. IN MF/D AND DC/W.
 E = ELECTROLYTIC.
 C = CERAMIC, FOLLOWED BY CAP. IN MMFD AND TOLERANCE IF CRITICAL.
 M = MCA, FOLLOWED BY CAP. IN MMFD AND TOLERANCE IF CRITICAL.

HUM BALANCE ADJUST R42 FOR MINIMUM HUM IN LEFT CHANNEL.
 ADJUST R41 FOR MINIMUM HUM IN RIGHT CHANNEL.

00-557-02 Issue 3