

# Electrohome Lonsdale

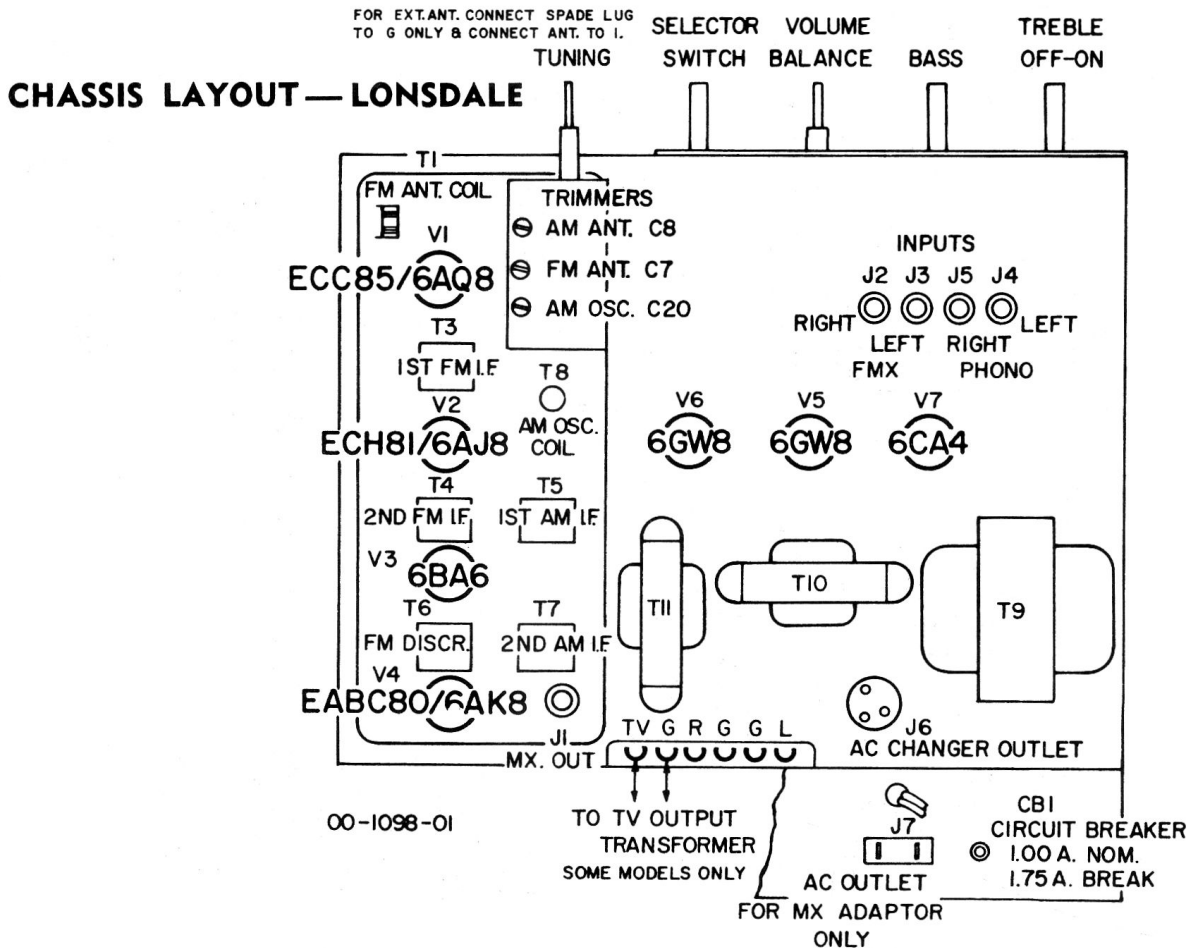

## AM-FM TUNER ALIGNMENT INSTRUCTIONS — LONSDALE

STEP	SERIES DUMMY ANTENNA	SIGNAL APPLIED TO	FREQ.	MODULATION	BAND SWITCH SETTING	DIAL POINTER SETTING	INDICATING METER	ADJUST	REMARKS	NOMINAL SENSITIVITY
1	.05 uf	Pin #1 V3 6BA6	455 Kc/s	400 C.P.S. AM at 30%	AM	600 Kc/s	AC-VTVM To Point "I"	T7 2nd AM-IF	Adjust for maximum output	2500 uv. for 40 Mv. output
2	.05 uf	Pin #2 V2 6AJ8	455 Kc/s	400 C.P.S. AM at 30%	AM	600 Kc/s	AC-VTVM To Point "I"	T5 1st AM-IF	Adjust for maximum output	25 uv. for 40 Mv. output
3	47 uuf	AM Ant. Term. Strip #1	600 Kc/s	400 C.P.S. AM at 30%	AM	600 Kc/s	AC-VTVM To Point "I"	T8 SLUG AM-Osc.	Adjust for Max. output.	-
4	47 uuf.	AM Ant. Term. Strip #1	1400 Kc/s	400 C.P.S. AM at 30%	AM	1400 Kc/s	AC-VTVM To Point "I"	C20 and C8 Trimmers	Adjust for Max. output.	-
5	Repeat steps 3 and 4, check band coverage at 535 Kc/s - 1650 Kc/s and for tracking at 950 Kc/s.									
6	-	Pin #2 V2 6AJ8	10.7 Mc/s	-	FM	Point of no interference	DC-VTVM Pin #2 T5	T4 2nd. FM-IF	Adjust for maximum meter deflection	-
7	-	C9A FM Gang	10.7 Mc/s	-	FM	Point of no interference	DC-VTVM Pin #2 T5	T3 1st. FM-IF	Adjust for maximum meter deflection	-
8	-	Pin #2 V2 6AJ8	10.7 Mc/s	-	FM	Point of no interference	DC-VTM Junction R16 & C34	T6 Primary Bottom Wdg.	Adjust for maximum meter deflection	-
9	-	Pin #2 V2 6AJ8	10.7 Mc/s	-	FM	Point of no interference	DC-VTM Junction R16 & C34 Note-2	T6 Secondary Top Wdg.	Adjust for zero voltage	-
10	Note 1	FM-Ant. Term.	90 Mc/s	22.5 Kc/s Dev. @ 400 C.P.S.	FM	90 Mc/s	AC-VTVM to Point "H"	L4 and T2 FM-RF and Osc. Coils	Adjust for maximum output	40 uv. for 100 Mv.
11	Note 1	FM-Ant. Term.	106 Mc/s	22.5 Kc/s Dev. @ 400 C.P.S.	FM	106 Mc/s	AC-VTVM to Point "H"	C7 and C15 trimmers	Adjust for maximum output	50 uv. for 100 Mv.
12	Repeat steps 10 and 11 and check for 20 db. quieting sensitivity.									

NOTES: 1. For FM Dummy antenna connect one 150 ohms carbon resistor from grounded side of sig. gen. to ant. term. and one 120 ohm carbon resistor from hot side of sig. gen. to ant. term.

2. With ground lead of DC-VTVM connected to junction of two 100K ohm resistors, which are to be connected across C36.

