

Electrohome Festival & Festival M

TUBE LAYOUT

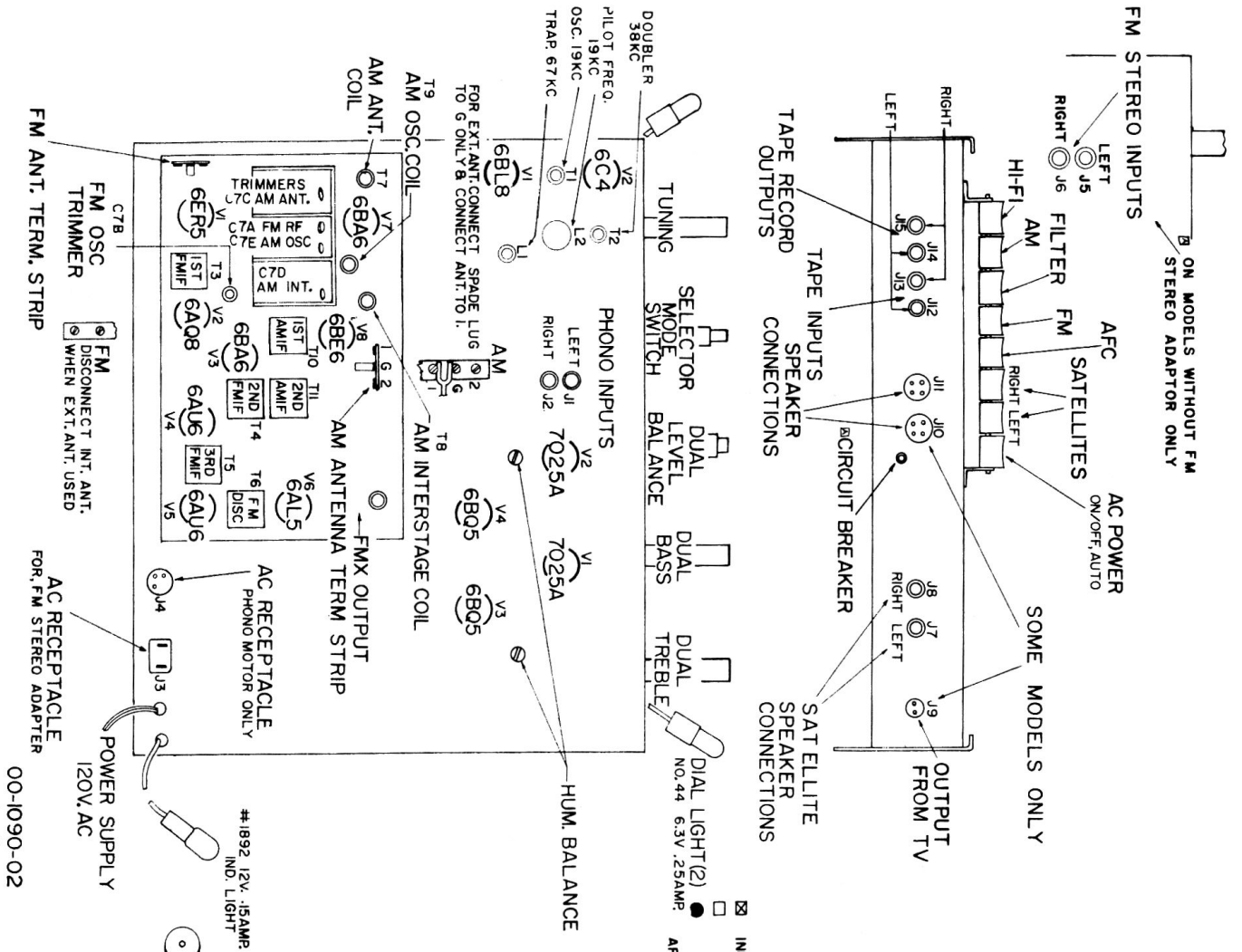

00-1090-02
Issue 2

SPEAKER CONNECTIONS

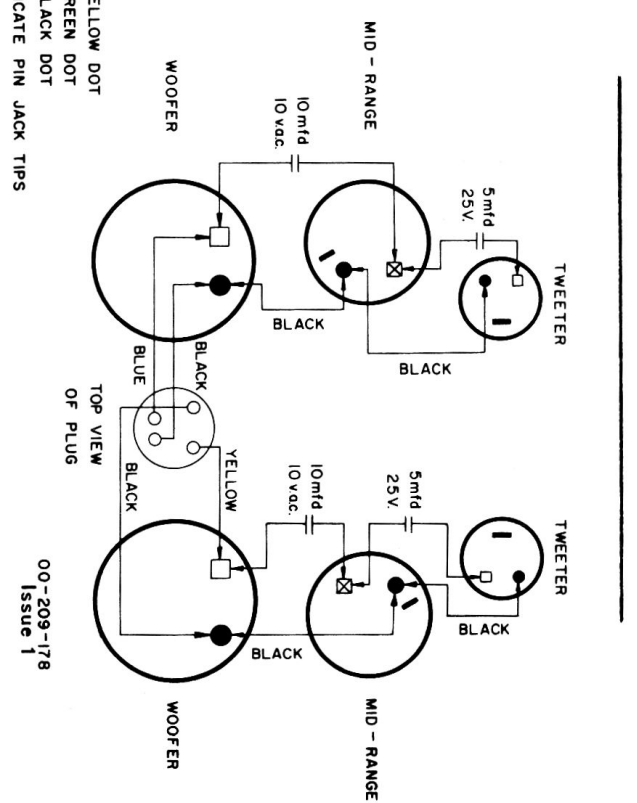

00-209-178
Issue 1

STRINGING DETAIL

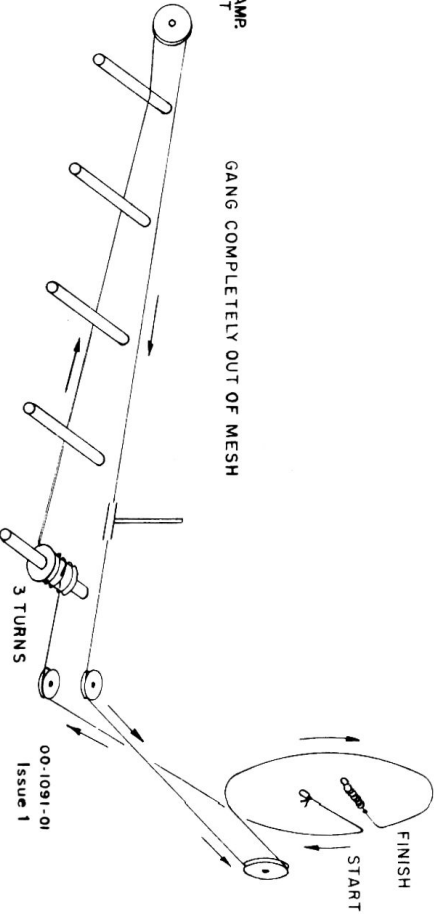

00-1091-01
Issue 1

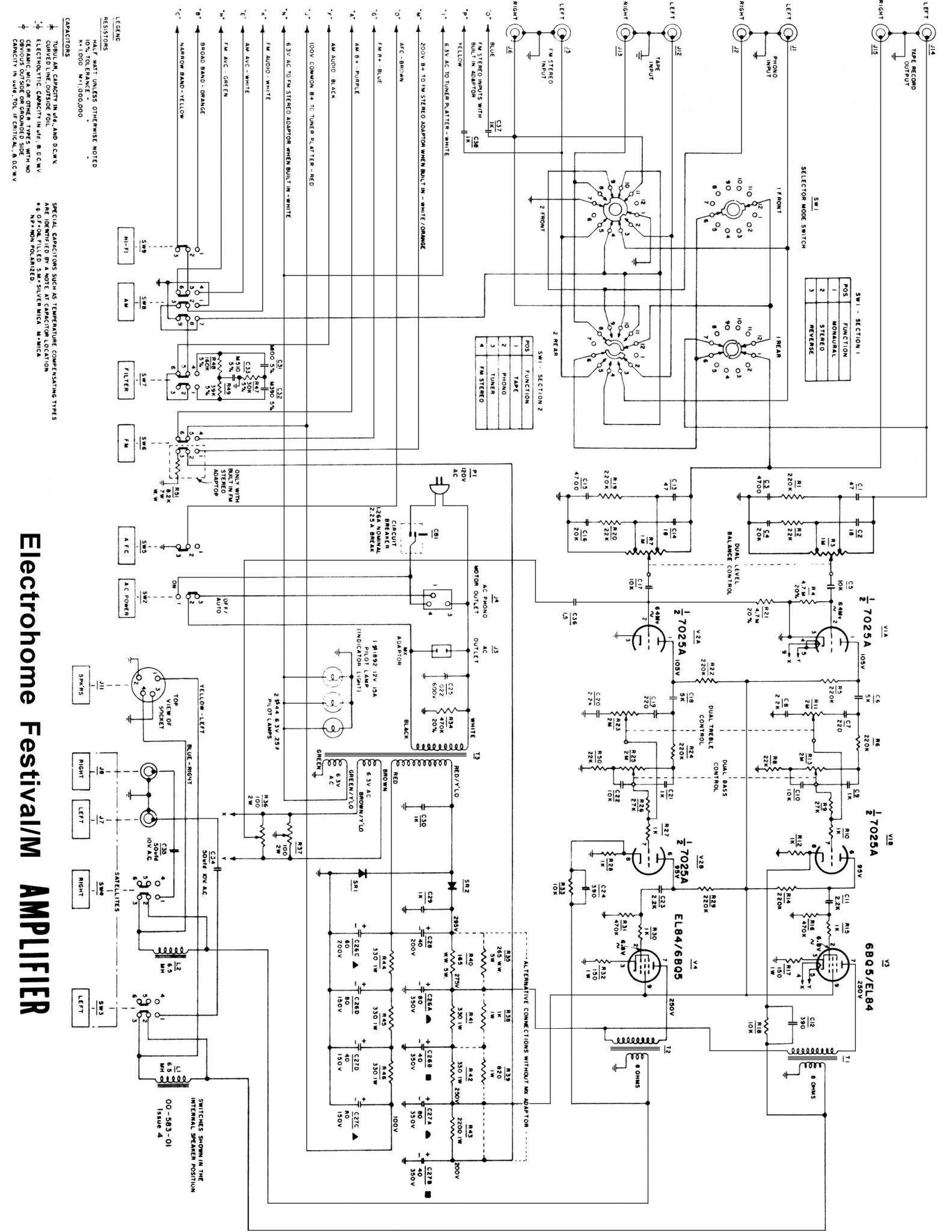

SW1 - SECTION 1

POS.	FUNCTION
1	MANUAL
2	STEREO
3	REVERSE

SW2 - SECTION 2

POS.	FUNCTION
1	TAPE
2	PHONO
3	TUNER
4	FM STEREO

LEGEND

RESISTORS
 10% TOLERANCE
 *1:1000 M:1000000

CAPACITORS

TUBULAR CAPACITY IN UF, AND D.C.W.V.
 CEN. LINE, OUTSIDE FOIL
 ELECTROLYTIC CAPACITY IN UF, D.C.W.V.
 CERAMIC MICA OR OTHER TYPES WITH NO
 CAPACITY IN UF, TOL. IF CRITICAL, D.C.W.V.

**SPECIAL CAPACITORS SUCH AS TEMPERATURE COMPENSATING TYPES
 ARE IDENTIFIED BY A NOTE AT CAPACITOR LOCATION**

*9: 0.7-0.8% TOLERANCE
 *N: NON-POLARIZED
 *M: MICA

Electrohome Festival/M AMPLIFIER

SWITCHES SHOWN IN THE
 INTERNAL BREAKER POSITION
 OO-583-01
 15400 4

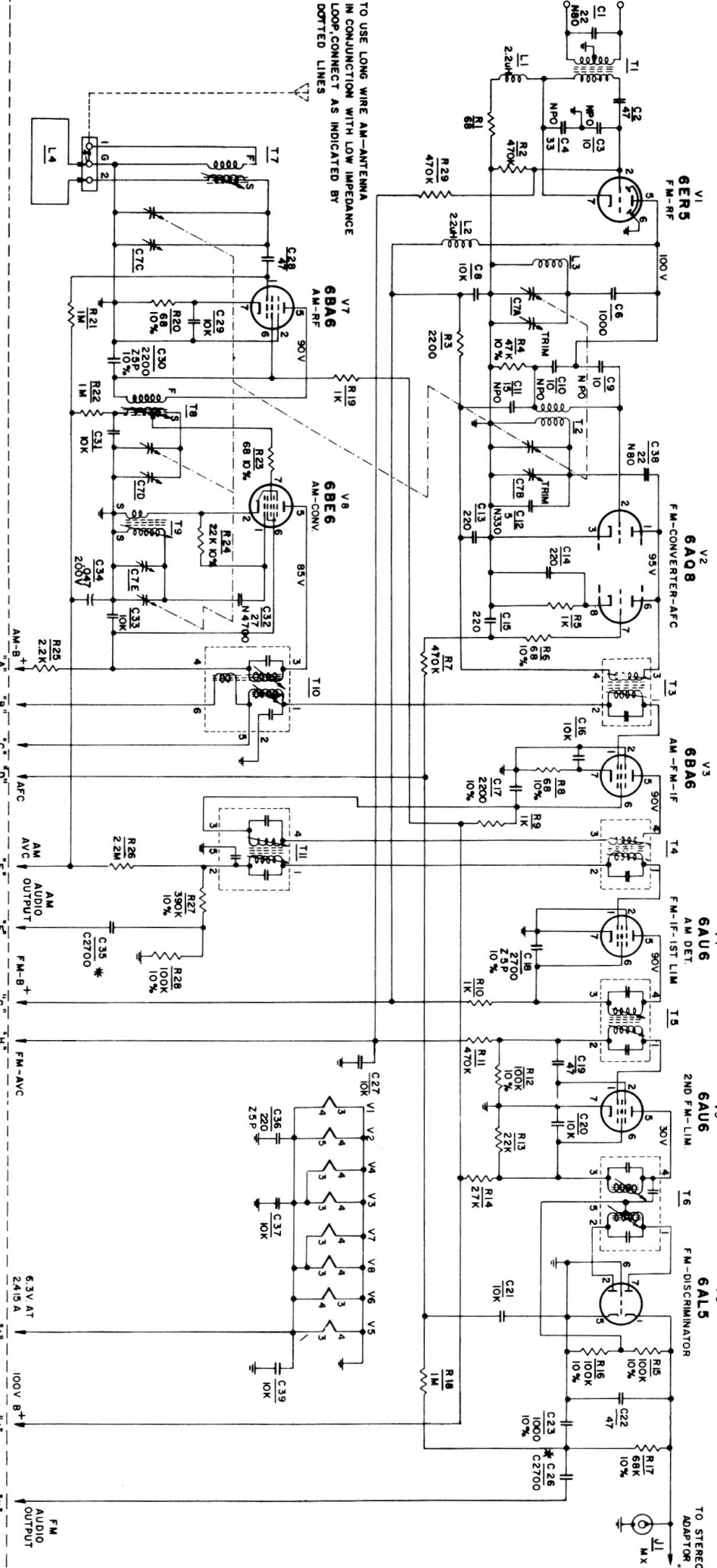

TO USE LONG WIRE AM-ANTENNA
IN CONNECTION WITH LOW IMPEDANCE
LOOP CONNECT AS INDICATED BY
DOTTED LINES

LEGEND
RESISTORS -
HALF WATT UNLESS OTHERWISE NOTED.
20% UNLESS OTHERWISE NOTED.
K=1,000 OHMS
M=1,000,000 OHMS

CAPACITORS
TUBULAR CAPACITY IN μ d., AND D.C. KW.
CURVED LINE-OUTSIDE FOR
ELECTROLYTIC CAPACITY IN μ d., AND D.C. KW.
CERAMIC, MICA OR OTHER TYPES WITH NO
OBVIOUS OUTSIDE OR GROUNDED SIDE
CAPACITY IN μ d., TOLERANCE IF CRITICAL
AND D.C. KW.

SPECIAL CAPACITORS SUCH AS TEMPERATURE
COMPENSATING TYPES ARE IDENTIFIED BY A
NO. IN AN ALIGNED LOCATION.
SM = SILVER MICA
M = MICA
N.P. = NON POLARIZED

NOTE 1-FOR ALIGNMENT INSTRUCTIONS SEE D.E.I. DWG 00-1908-01
NOTE 2- 10K ON ALL 6 WATT MODELS.

Electrohme Festival/AM-FM TUNER SCHEMATIC

STEP	DUMMY ANTENNA	SIGNAL APPLIED TO	FREQ.	MODULATION	BAND SWITCH SETTING	DIAL POINTER SETTING	INDICATING METER	ADJUST	REMARKS	NOMINAL SENSITIVITY
1	.05 uf	Pin No. 1 V3 6BA6	455 Kc/s	400 c.p.s. AM at 30%	AM	600 Kc/s	AC-VTVM To Point "F"	T11 2nd. AM-IF	Adjust for maximum output.	4000 uv for 20 mv output
2	.05 uf	Pin No. 7 V8 6BE6	455 Kc/s	400 c.p.s. AM at 30%	AM	600 Kc/s	AC-VTVM To Point "F"	T10 1st. AM-IF	Adjust for maximum output.	300 uv for 20 mv output
3	Change Band Switch Setting to (AM Hi-Fi) Tune Signal Generator across 440-470 Kc/s Frequency Range and check for approx. response curve as shown. This test should preferably be made with a proper sweep Generator and Scope.									
4	200 uf	AM Ant. Term. Strip No. 1	600 Kc/s	400 c.p.s. AM at 30%	AM	600 Kc/s	AC-VTVM To Point "F"	T7, T8, and T9	Connect for long wire antenna, adjust for maximum output.	2.5 uv for 20 mv output
5	200 uf	AM Ant. Term. Strip No. 1	1400 Kc/s	400 c.p.s. AM at 30%	AM	1400 Kc/s	AC-VTVM To Point "E"	C1C, C1D, and C1E Trimmers	Connect for long wire antenna, adjust for maximum output.	1.8 uv for 20 mv output
6	Repeat steps 4 and 5, check for band coverage at 535 Kc/s - 1650 Kc/s and for tracking at 950 Kc/s.									
7	-	Pin No. 1 V4 6AU6	10.7 Mc/s	-	FM	Point of no Interference	DC-VTVM To Point "H"	T5 3rd. FM-IF	Adjust for maximum meter deflection.	15000 uv for 1V output
8	-	Pin No. 1 V4 6AU6	10.7 Mc/s	-	FM	Point of no Interference	DC-VTVM to Pin No.5 of T6	T6 FM Discriminator Primary	Adjust for maximum meter deflection.	10000 uv for 3V output
10	-	Pin No. 1 V3 6BA6	10.7 Mc/s	-	FM	Point of no Interference	DC-VTVM To Point "H"	T4 2nd FM-IF	Adjust for maximum meter deflection	250 uv for 1V output
11	-	C1A FM Gang	10.7 Mc/s	-	FM	Point of no Interference	DC-VTVM To Point "H"	T3 1st FM-IF	Adjust for maximum meter deflection.	-
12	*	FM Ant. Term. Strip	90 Mc/s	400 c.p.s. FM 22.5 Kc/s Deviation	FM	90 Mc/s	AC-VTVM To Point "K"	Expand or compress L3 and T2	Adjust for maximum output.	3 uv for 100 mv output
13	*	FM Ant. Term. Strip	106 Mc/s	400 c.p.s. FM 22.5 Kc/s Deviation	FM	106 Mc/s	AC-VTVM To Point "K"	C1B and C1A Trimmers	Adjust for maximum output.	3 uv for 100 mv output
14	Repeat steps 12 and 13 until output drops at least 20 db. when mod. is turned off.									

NOTE: To achieve more accurate alignment of FM IF's and Discriminator it is preferable to use a proper sweep generator and oscilloscope.

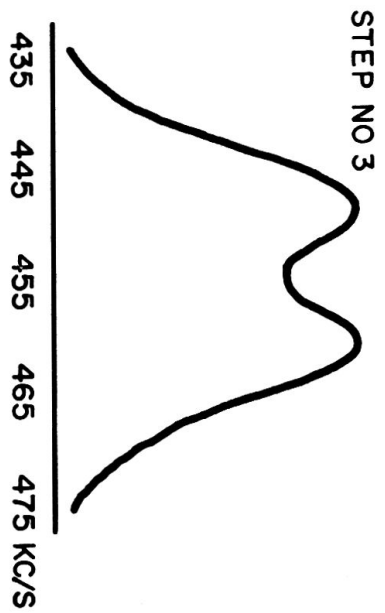

* For FM dummy antenna connect one 150 Ω carbon resistor from grounded side of sig. gen. to ant. term., and one 120 Ω carbon resistor from hot side of sig. gen. to ant. term.

Electrohome Festival/AM-FM TUNER ALIGNMENT