

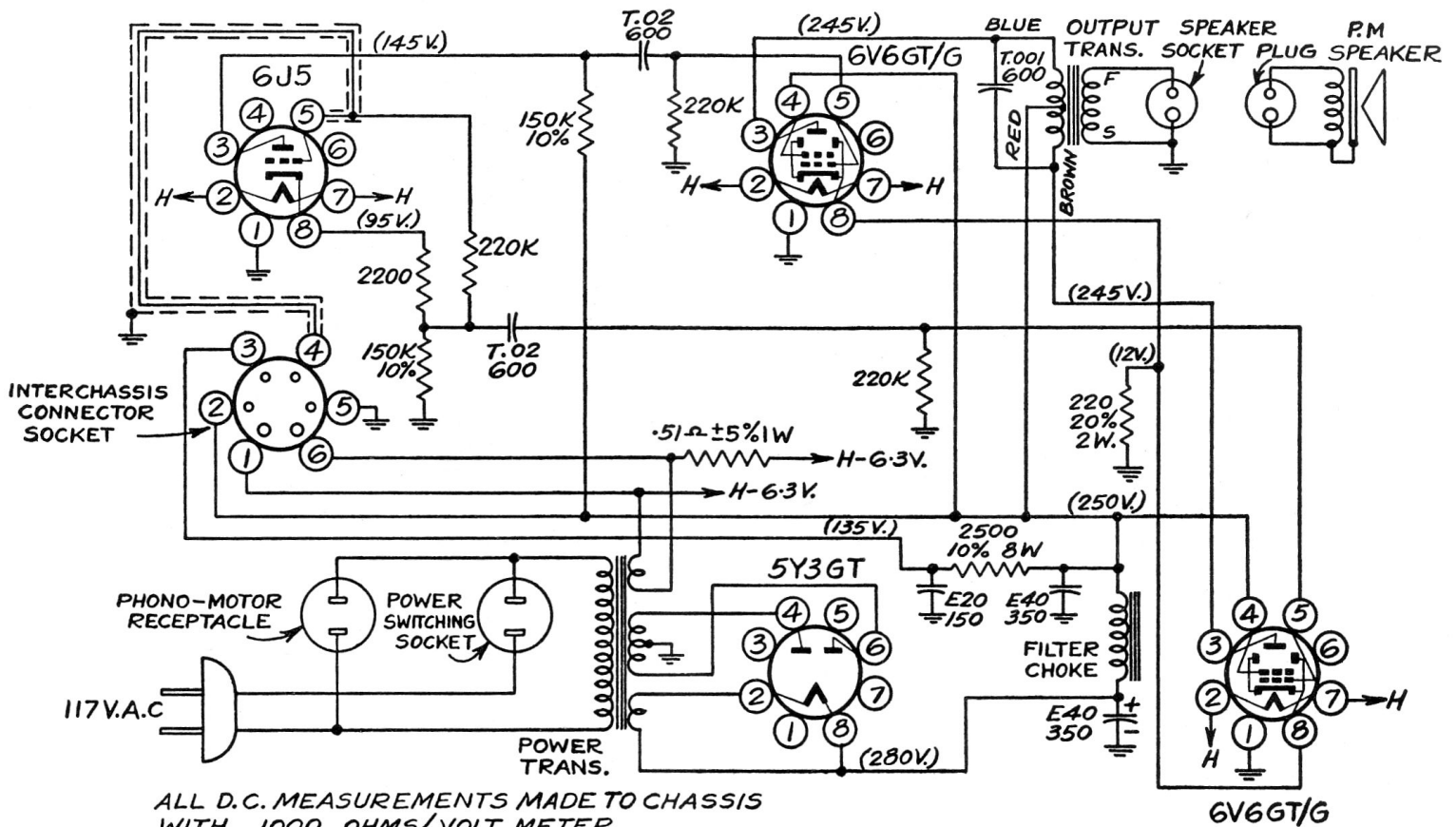

# Electrohome Chippendale FM 11 Tuner Power Supply/Amp



## COMPONENT VALUES.

- RESISTORS: HALF WATT UNLESS OTHERWISE NOTED.  
 20% TOLERANCE UNLESS OTHERWISE NOTED.  
 K = 1000 OHMS.  
 M = 1,000,000 OHMS.
- CONDENSERS: T = TUBULAR, FOLLOWED BY CAP. IN MFD. & D.C.W.V.  
 E = ELECTROLYTIC, FOLLOWED BY CAP. IN MFD. & D.C.W.V.

J-3040

## ANTENNA AND GROUND CONNECTIONS

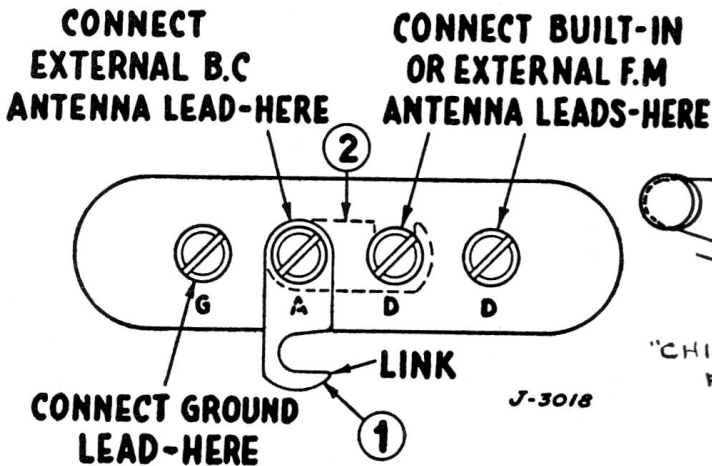

## GANG COMPLETELY IN MESH

