

FM STEREO RADIO ADAPTER SCHEMATIC (CASTILIAN)

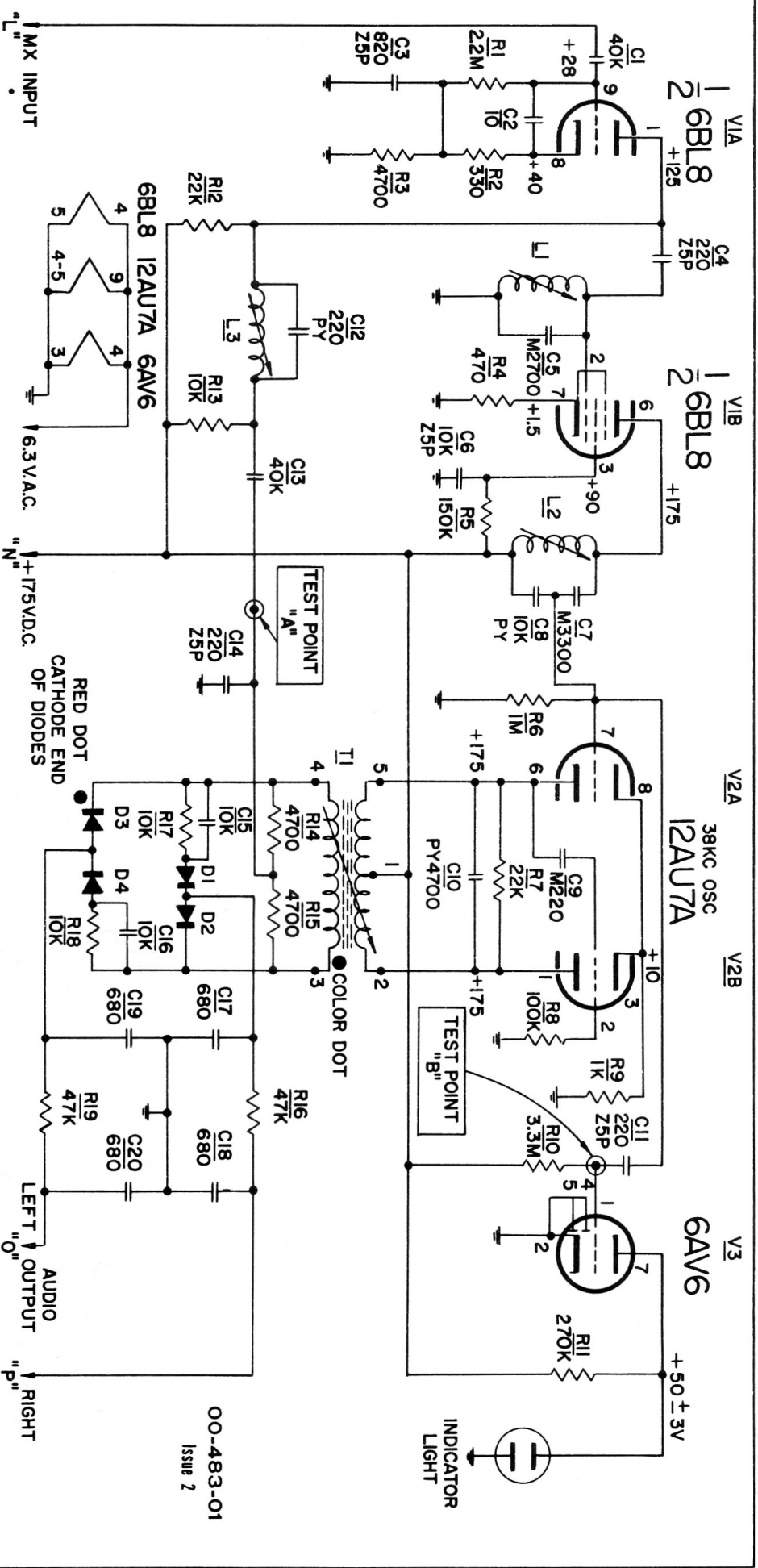

00-483-01
Issue 2

ALIGNMENT - EQUIPMENT, MX GENERATOR, SCOPE, AC-VTVM, AUDIO GENERATOR

INPUT	INPUT LEVEL	OUTPUT CONN.	SCOPE OR AC-VTVM WITH OSC TUBE REMOVED	ADJUST
1 67KC ± 1KC	10V - RMS	TEST PT "A"	SCOPE OR AC-VTVM WITH OSC TUBE REMOVED	L3 FOR MINIMUM
2 19KC ± 3CY	200MV	TEST PT "B"	SCOPE OR AC-VTVM	L1 & L2 FOR MAX
3 MX GEN. 10% 19KC & LEFT CH. AUDIO ONLY	200MV	LEFT & RIGHT OUTPUTS *	SCOPE WITH OSC. TUBE REPLACED	T1 FOR STEADY PAT. (OSC LOCKED IN)
4 AS ABOVE	1V	AS ABOVE	AS ABOVE	L2 FOR MAXIMUM SEPARATION NOT OVER 1/4 TURN FROM SETTING IN STEP 2
5 REPEAT STEPS 3 AND 4 FOR MAXIMUM SEPARATION				
* THRU ELECTRONIC SWITCH OR MANUAL SWITCH				

LEGEND

- RESISTORS**
 HALF WATT UNLESS OTHERWISE NOTED.
 10% TOLERANCE UNLESS OTHERWISE NOTED.
- CAPACITORS**
 TUBULAR, CAPACITY IN ufd, & D.C.W.V.
 CURVED LINE OUTSIDE FOIL.
 ELECTROLYTIC, CAPACITY IN ufd, & D.C.W.V.
 CERAMIC, MICA, OR OTHER TYPES WITH NO OBVIOUS OUTSIDE OR GROUNDED SIDE, CAPACITY IN ufd, TOLERANCE IF CRITICAL, & D.C.W.V.
- SPECIAL CAPACITORS SUCH AS TEMPERATURE COMPENSATING TYPES ARE IDENTIFIED BY A NOTE AT CAPACITOR LOCATION.**
 eg OF = OIL FILLED
 S.M. = SILVER MICA
 M = MICA
 N.P. = NON POLARIZED
 P.Y. = POLYSTYRENE

AMPLIFIER SCHEMATIC (CASTILIAN)

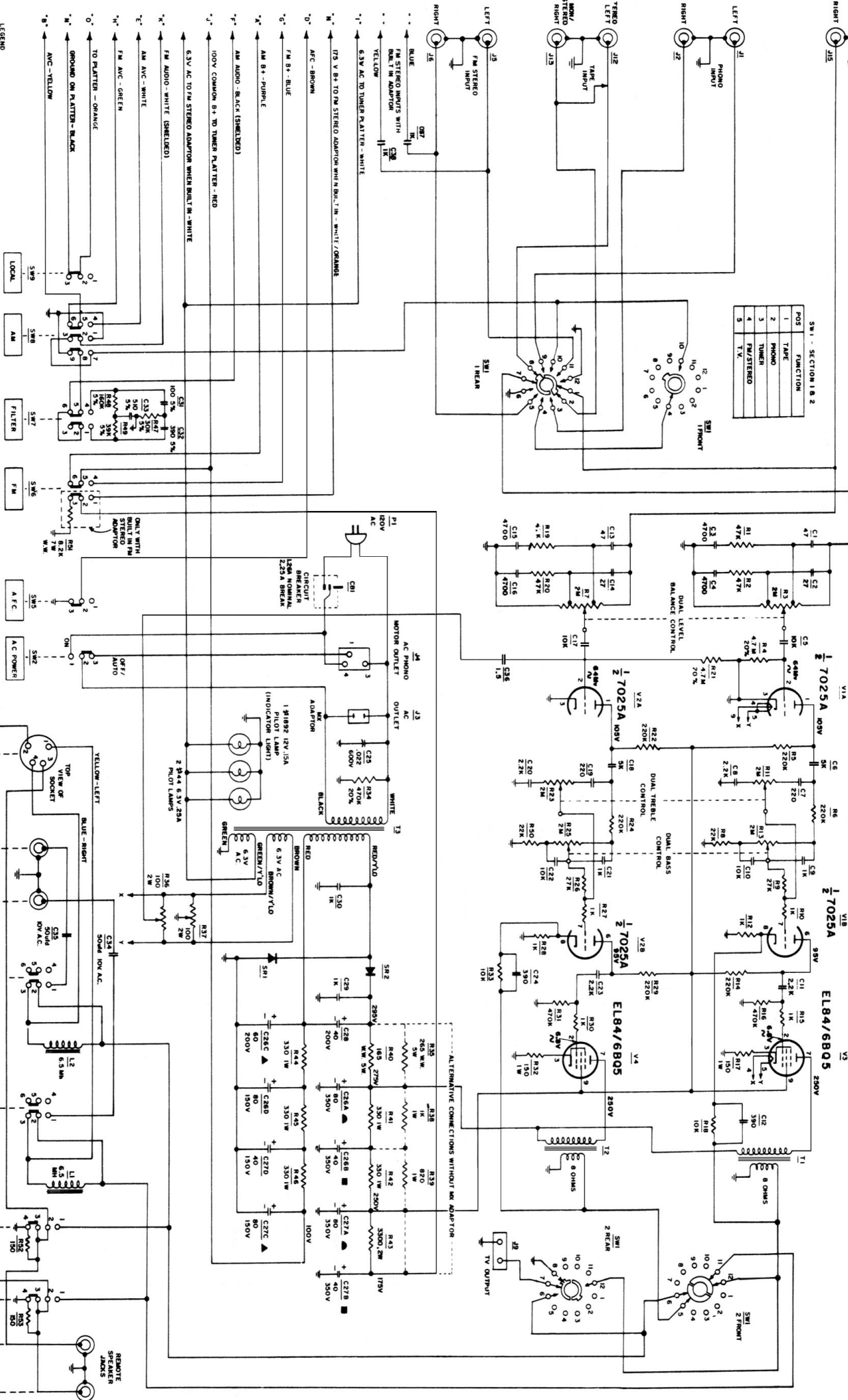

SW1 - SECTION 1 & 2

POS	FUNCTION
1	TAPE
2	PHONO
3	TUNER
4	FM/STEREO
5	T.V.

LEGEND

RESISTORS
 HALF WATT UNLESS OTHERWISE NOTED
 10% TOLERANCE -
 M-1,000 M-1,000,000

CAPACITORS

TUBULAR CAPACITY IN uF, AND D.C.W.
 CURVED LINE OUTSIDE FOIL
 ELECTROLYTIC CAPACITY IN uF, D.C.W.
 CERAMIC MICA OR OTHER TYPE'S WITH NO
 CAPACITY IN uF, D.C.W. IN PARENTHESES, D.C.W.

SPECIAL CAPACITORS SUCH AS TEMPERATURE COMPENSATING TYPES

ARE IDENTIFIED BY A NOTE AT CAPACITOR LOCATION

4.9 OF .01 OHM FILLED 5.6K SILVER MICA M-MICA
 N-7 NON-POLARIZED

00-590-03
 [REV 3]

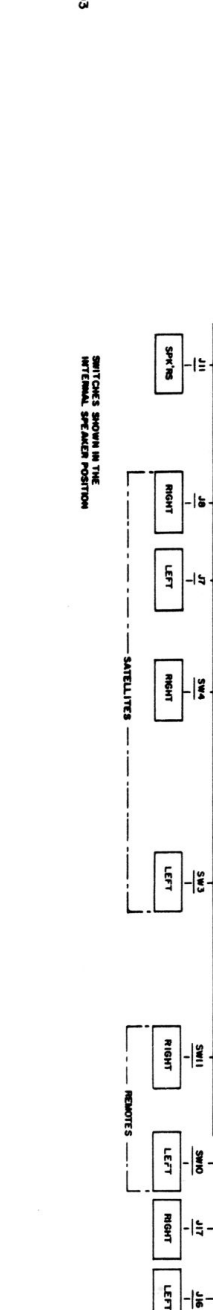

AM-FM TUNER SCHEMATIC (CASTILIAN)

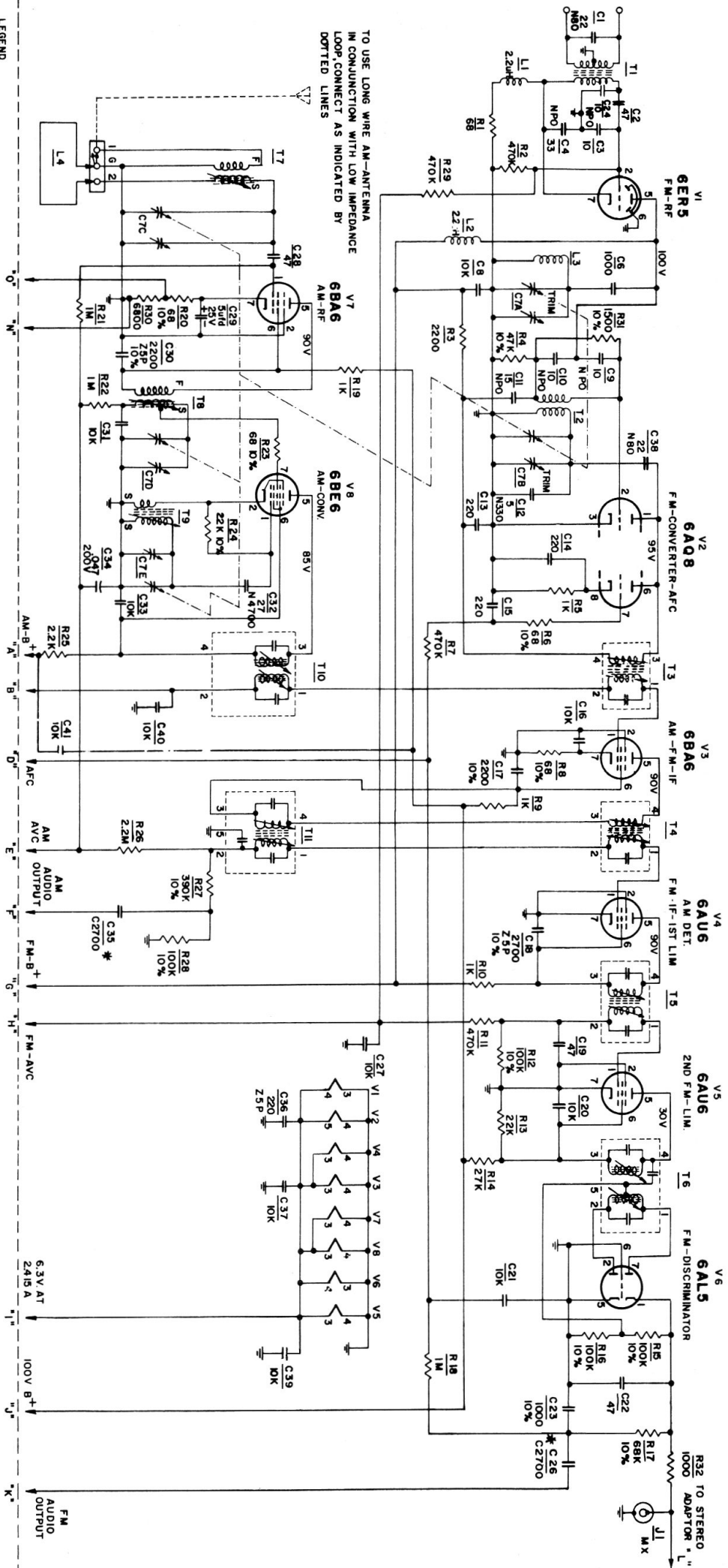

TO USE LONG WIRE AM-ANTENNA
IN CONJUNCTION WITH LOW IMPEDANCE
LOOP, CONNECT AS INDICATED BY
DOTTED LINES

LEGEND
RESISTORS -
HALF WATT UNLESS OTHERWISE NOTED.
20% UNLESS OTHERWISE NOTED.
K=1,000 OHMS
M=1,000,000 OHMS

CAPACITORS
TUBULAR CAPACITY IN ufd. AND D.C.W.V.
TRIMMED LINE-OUTSIDE FOIL
ELECTROLYTIC CAPACITY IN ufd. AND D.C.W.V.
GERMANIC, MICA, OR OTHER TYPES WITH NO
CAPACITORS OUTSIDE OR GROUNDED SIDE
AND D.C.W.V. TOLERANCE IF CRITICAL

SPECIAL CAPACITORS SUCH AS TEMPERATURE
COMPENSATING TYPES ARE IDENTIFIED BY A
NOTE AT CAPACITOR LOCATION.
86 D.P. OIL FILLED
SM. SILVER MICA
M= MICA
NP= NON POLARIZED

NOTE 1-FOR ALIGNMENT INSTRUCTIONS SEE D.E.I. DWG. 00-1909-01 00-449-02
NOTE 2-10K ON ALL 6 WATT MODELS.
ISSUE 7

AM-FM TUNER ALIGNMENT INSTRUCTIONS (CASTILIAN)

STEP	DUMMY ANTENNA	SIGNAL APPLIED TO	FREQ.	MODULATION	BAND SWITCH SETTING	DIAL POINTER SETTING	INDICATING METER	ADJUST	REMARKS	NOMINAL SENSITIVITY
1	.05 uf	Pin # 1 V3 6BA6	455 Kc/s	400 C.P.S. AM at 30%	AM	600 Kc/s	AC-VTVM To Point "F"	T11, 2nd AM-IF	Adjust for maximum output	4000 uv for 20 mv output
2	.05 uf	Pin # 7 V8 6BE6	455 Kc/s	400 C.P.S. AM at 30%	AM	600 Kc/s	AC-VTVM To Point "F"	T10, 1st AM-IF	Adjust for maximum output	300 uv for 20 mv output
3	** 200 uf	AM Ant Term Strip # 1	600 Kc/s	400 C.P.S. AM at 30%	AM	600 Kc/s	AC-VTVM To Point "F"	T7, T8, and T9	Connect for long wire antenna, adjust for maximum output.	2.5 uv for 20 mv output
4	** 200 uf	AM Ant Term Strip # 1	1400 Kc/s	400 C.P.S. AM at 30%	AM	1400 Kc/s	AC-VTVM To Point "F"	C1C, C1D and C1E Trimmers	Connect for long wire antenna, adjust for maximum output	1.8 uv for 20 mv output
5	Repeat steps 3 and 4, check for band coverage at 535 Kc/s - 1650 Kc/s and for tracking at 950 Kc/s.									
6	When local switch is depressed, sensitivity is reduced by approximately ten times.									
7		Pin # 1 V4 6AU6	10.7 Mc/s	---	FM	Point of no inter- ference	DC-VTVM To Point "H"	T5, 3rd FM-IF	Adjust for maximum meter deflection	15000 uv for 1V output
8		Pin # 1 V4 6AU6	10.7 Mc/s	---	FM	Point of no inter- ference	DC-VTVM To Pin # 5 of T6	T6, FM Discriminator Primary	Adjust for maximum meter deflection	*** 10000 uv for 3V output
9		Pin # 1 V4 6AU6	10.7 Mc/s	---	FM AFC	Point of no inter- ference	DC-VTVM To Point "D"	T6, FM Discriminator Secondary	Adjust for zero voltage	---
10		Pin # 1 V3 6BA6	10.7 Mc/s	---	FM	Point of no inter- ference	DC-VTVM To Point "H"	T4, 2nd FM-IF	Adjust for maximum meter deflection	250 uv for 1V output
11		C1A FM Gang	10.7 Mc/s	---	FM	Point of no inter- ference	DC-VTVM To Point "H"	T3, 1st FM-IF	Adjust for maximum meter deflection	---
12	*	FM Ant. Term Strip	90 Mc/s	400 C.P.S. FM 22.5 Kc/s Deviation	FM	90 Mc/s	AC-VTVM To Point "K"	Expand or compress L3 and T2	Adjust for maximum output	3.0 uv for 100 mv output
13	*	FM Ant. Term Strip	106 Mc/s	400 C.P.S. FM 22.5 Kc/s Deviation	FM	106 Mc/s	AC-VTVM To Point "K"	C1A and C1B Trimmers	Adjust for maximum output	3.0 uv for 100 mv output
14	Repeat steps 12 and 13 until output drops at least 20 db when mod. is turned off.									

NOTE: - To achieve more accurate alignment of FM IF's and discriminator it is preferable to use a proper sweep generator & oscilloscope.

2.0 uv

* For FM dummy antenna connect one 150 ohm carbon resistor from grounded side of sig. gen. to antenna terminal and one 120 ohm carbon resistor from hot side of signal generator to antenna terminal.

** These steps to be made with local-distance switch in distance position. Connect 47K ohm resistor to Pin #5 of T6 for this measurement.

00-1909-02
Issue 2