

AM-FM TUNER ALIGNMENT

Electrohome Cascade

STEP	DUMMY ANTENNA	SIGNAL APPLIED TO	FREQ.	MODULATION	BAND SWITCH SETTING	DIAL POINTER SETTING	INDICATING METER	ADJUST	REMARKS	NOMINAL SENSITIVITY
1	.05 uf	Pin #1 V3 6BA6	455 Kc/s	400 C.P.S. AM at 30%	AM	600 Kc/s	AC-VTVM To Point "I"	T7 2nd AM-IF	Adjust for maximum output	2500 uv. for 40 Mv. output
2	.05 uf	Pin #2 V2 6AJ8	455 Kc/s	400 C.P.S. AM at 30%	AM	600 Kc/s	AC-VTVM To Point "I"	T5 1st AM-IF	Adjust for maximum output	25 uv. for 40 Mv. output
3	200 uuf	AM Ant. Term. Strip #1	600 Kc/s	400 C.P.S. AM at 30%	AM	600 Kc/s	AC-VTVM To Point "I"	T9 and T8 AM-Osc. & AM Ant.	Connect for long wire ant. Adjust for Max. output. **	12 uv. for 40 Mv. output
4	200 uuf	AM Ant. Term. Strip #1	1400 Kc/s	400 C.P.S. AM at 30%	AM	1400 Kc/s	AC-VTVM To Point "I"	C1B & C1D Trimmers	Connect for long wire ant. Adjust for Max. output. **	15 uv. for 40 Mv. output
5 Repeat steps 3 and 4, check band coverage at 535 Kc/s - 1650 Kc/s and for tracking at 950 Kc/s.										
6	-	Pin #2 V2 6AJ8	10.7 Mc/s	-	FM	Point of no interference	DC-VTVM Pin #2 T5	T4 2nd. FM-IF	Adjust for maximum meter deflection	9000 uv. for 1 volt.
7	-	C1C FM Gang	10.7 Mc/s	-	FM	Point of no interference	DC-VTVM Pin #2 T5	T3 1st. FM-IF	Adjust for maximum meter deflection	-
8	-	Pin #2 V2 6AJ8	10.7 Mc/s	-	FM	Point of no interference	DC-VTVM Junction R14 and C26	T6 Primary Bottom Wdg.	Adjust for maximum meter deflection	2500 uv. for 3 volts.
9	-	Pin #2 V2 6AJ8	10.7 Mc/s	-	FM	Point of no interference	" "	T6 Secondary Top Wdg.	Adjust for zero voltage	-
10	*	FM-Ant. Term.	90 Mc/s	22.5 Kc/s Dev. @ 400 C.P.S.	FM	90 Mc/s	AC-VTVM to Point "H"	L3 and T2 FM-RF and Osc. Coils	Adjust for maximum output	40 uv. for 100 Mv.
11	*	FM-Ant. Term.	106 Mc/s	22.5 Kc/s Dev. @ 400 C.P.S.	FM	106 Mc/s	AC-VTVM to Point "H"	C1C & C1A trimmers	Adjust for maximum output	50 uv. for 100 Mv.
12 Repeat steps 10 and 11 and check for 20 db. quieting sensitivity.										5-6 uv.

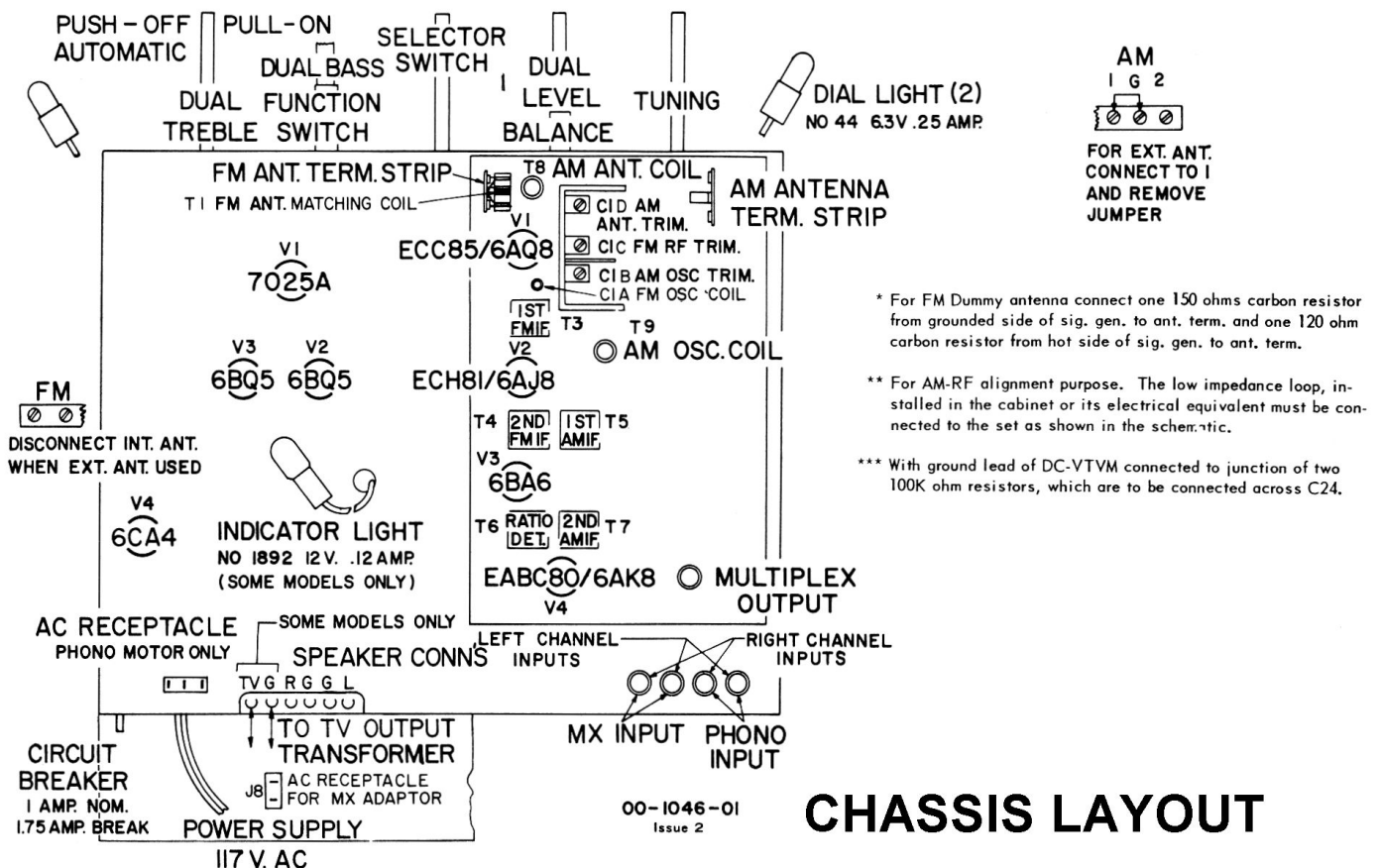

* For FM Dummy antenna connect one 150 ohms carbon resistor from grounded side of sig. gen. to ant. term. and one 120 ohm carbon resistor from hot side of sig. gen. to ant. term.

** For AM-RF alignment purpose. The low impedance loop, installed in the cabinet or its electrical equivalent must be connected to the set as shown in the schematic.

*** With ground lead of DC-VTVM connected to junction of two 100K ohm resistors, which are to be connected across C24.

AM-FM TUNER

V1 FM CONVERTER
ECC85/6A08

V2 AM-CONV. 1st FM IF
ECH81/6AU8

V3 AM-FM IF
6BA6

V4 AM FM DETECTOR
EABC80/6AK8

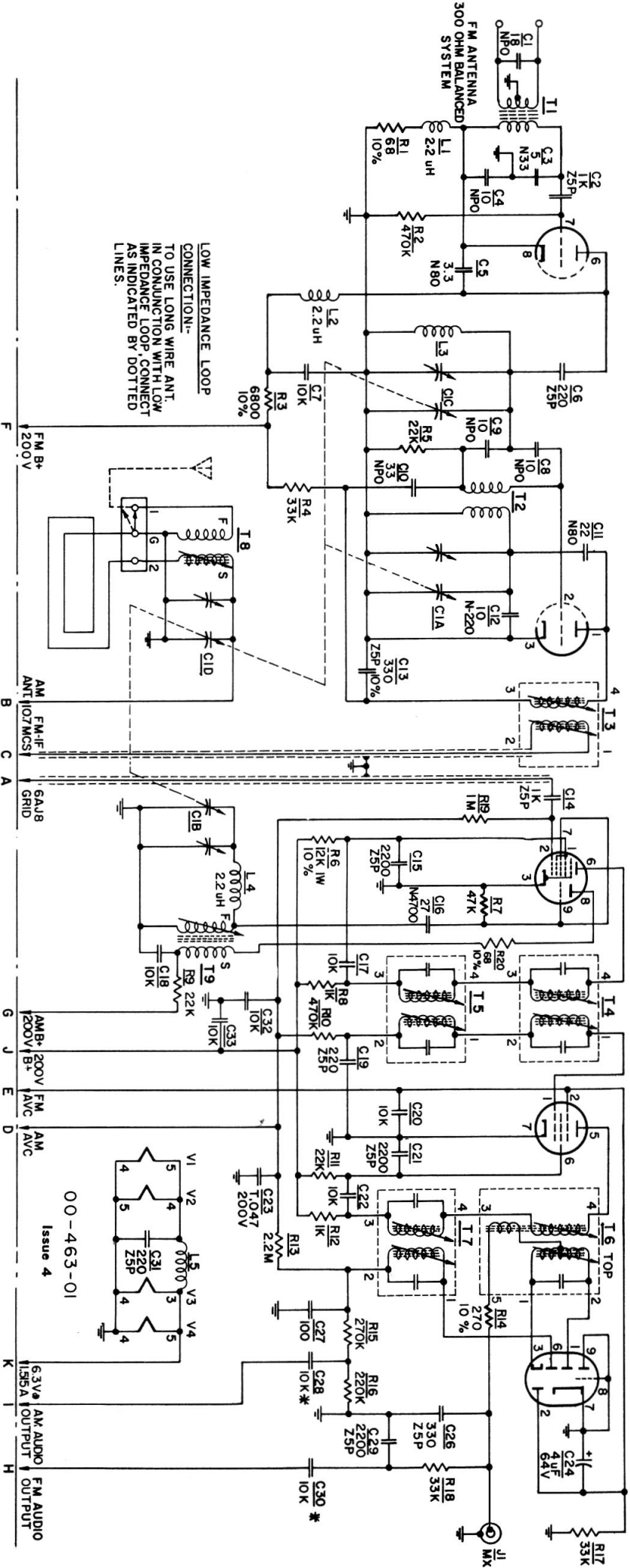

LOW IMPEDANCE LOOP CONNECTION:-
TO USE LONG WIRE ANT IN CONJUNCTION WITH LOW IMPEDANCE LOOP, CONNECT AS INDICATED BY DOTTED LINES.

LEGEND:

- RESISTORS**
HALF WATT UNLESS OTHERWISE NOTED.
20% TOLERANCE UNLESS OTHERWISE NOTED.
K = 1,000
M = 1,000,000
- CAPACITORS**
TUBULAR CAPACITY IN ufd. AND DC.W.V.
CURVED LINE, OUTSIDE FOIL.
ELECTROLYTIC CAPACITY IN ufd. AND DC.W.V.
OBLIQUE OUTSIDE OR GROUND SIDE.
CAPACITY IN ufd., TOLERANCE IF CRITICAL AND DC.W.V.

SPECIAL CAPACITORS SUCH AS TEMPERATURE COMPENSATING TYPES ARE IDENTIFIED BY A NOTE AT CAPACITOR LOCATION
e.g. - OF = OIL FILLED
SM = SILVER MICA
M = MICA
NP = NON POLARIZED
TEMPERATURE COEFFICIENTS - (N.P.O., N-, P-)

NOTE:-
FOR ALIGNMENT INSTRUCTIONS SEE D.I.E. DRAWING NO. 00-8906-01.
* C2700 ON SOME MODELS

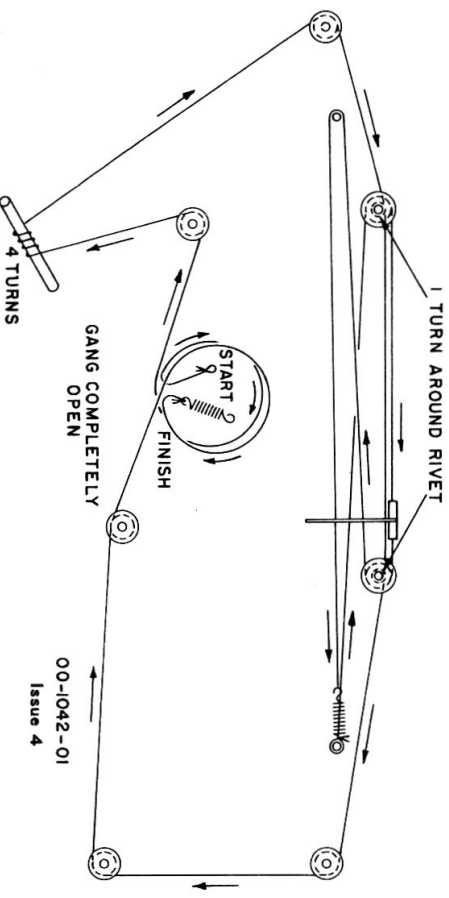

Electrohome Cascade

00-1042-01
Issue 4

