

**BOGEN
MODEL MO30**

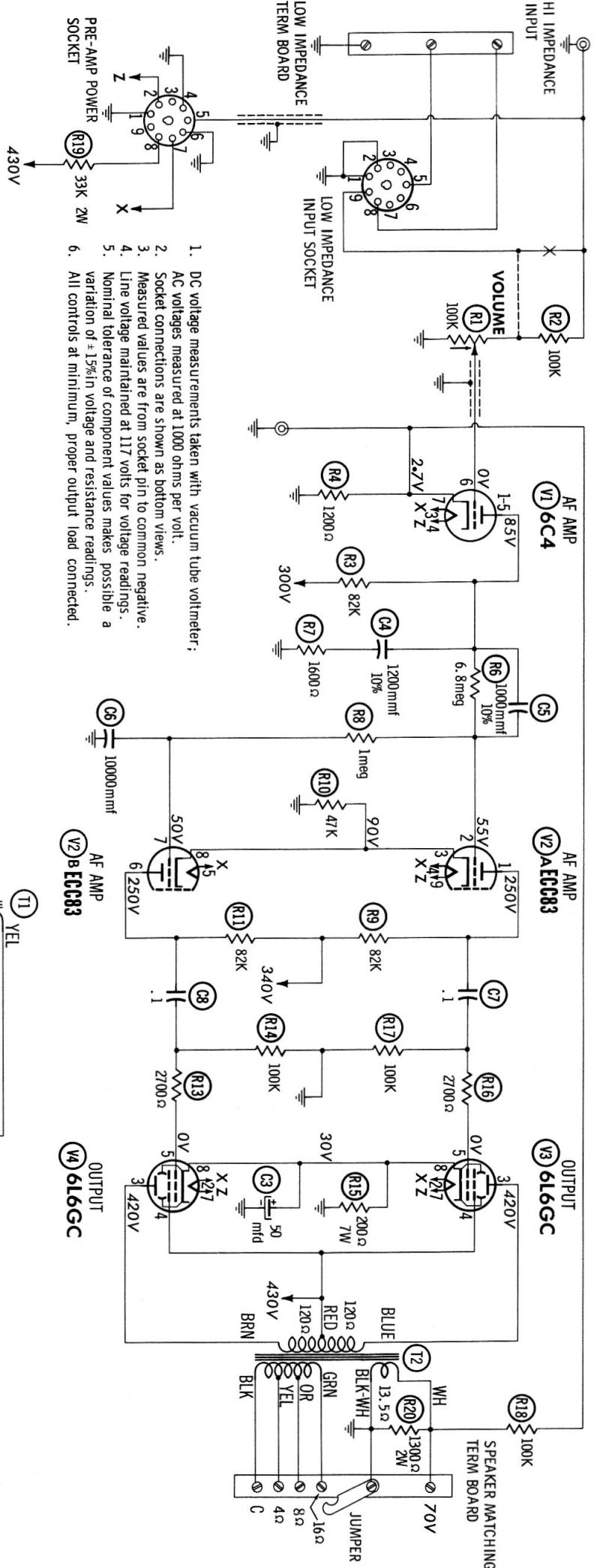

1. DC voltage measurements taken with vacuum tube voltmeter;
2. AC voltages measured at 1000 ohms per volt.
3. Socket connections are shown as bottom views.
4. Measured values are from socket pin to common negative.
5. Line voltage maintained at 117 volts for voltage readings.
6. Nominal tolerance of component values makes possible a variation of $\pm 15\%$ in voltage and resistance readings.
7. All controls at minimum, proper output load connected.

