

ALL RESISTORS IN OHMS
 M = 1,000,000 OHMS
 K = 1,000 OHMS
 ALL CAPACITORS MFD
 UNLESS MARKED PF (MMFD)

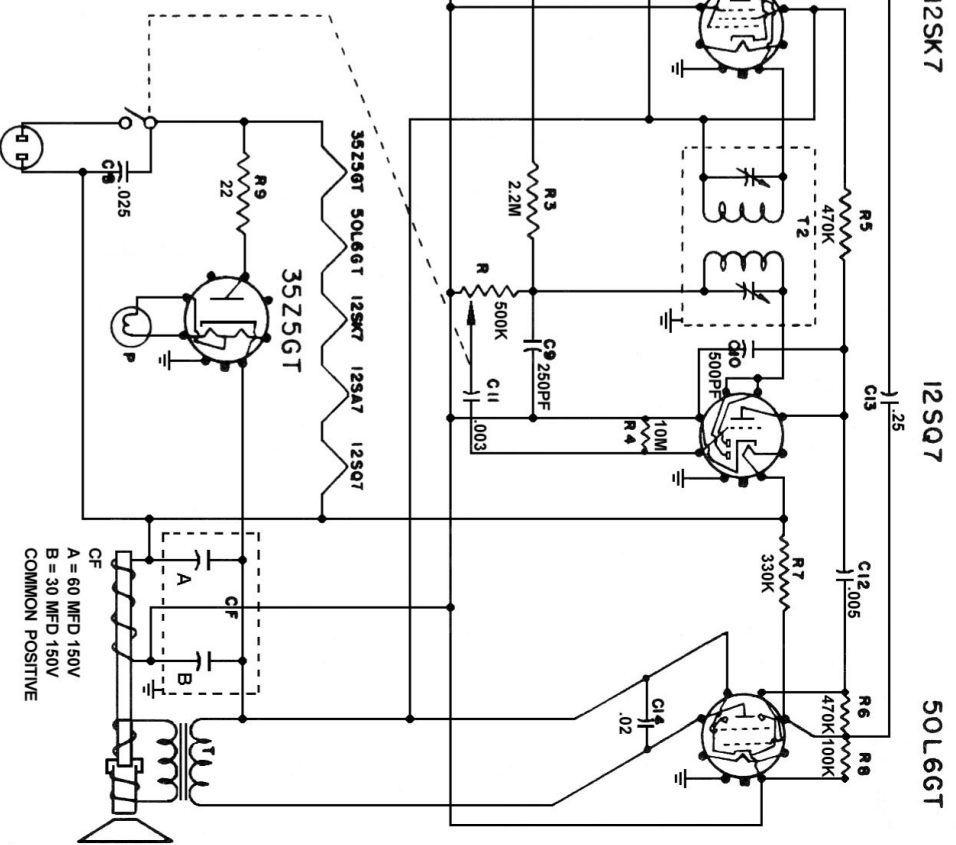

Addison 5A to 5F

CF
 A = 60 MFD 150V
 B = 30 MFD 150V
 COMMON POSITIVE

1. TUNING I.F. AMPLIFIER TO 456 KILOCYCLES

- (a) Connect the Output from the Signal Generator through a 60 mmf. mica condenser to the lead provided for use of an external antenna.
- (b) Connect the Output Meter across the voice coil.
- (c) Turn the control situated at the left on front of chassis (On-Off switch and Volume Control) to its maximum clockwise position and the Tuning Control so that the plates are completely in mesh.
- (d) Set Generator to 456 Kilocycles.
- (e) Adjust both trimmers located on top of the 2nd I.F. Transformer (T2) until maximum deflection is obtained on the Output Meter.
- (f) Adjust both trimmers located on top of the 1st I.F. Transformer (T1) until maximum deflection is obtained.

N.B.:

After each adjustment has been made it may be necessary to re-adjust the Generator Attenuator to a reasonable output.

2. BROADCAST ALIGNMENT

- (a) Leave Generator and Output Meter connected as described in the Tuning of the I.F. Amplifier.
- (b) Set Signal Generator to 1500 K.C. and Tuning Condenser for a corresponding dial reading.
- (c) Adjust the Oscillator Trimmer situated on the top right side of chassis through the 3rd opening from front until deflection is obtained on the Output Meter.
- (d) Now adjust the Mixer Trimmer situated on the back of the Loop Antenna until maximum deflection is obtained on the Output Meter.
- (e) If adjustment should be necessary at the low frequency end of the Broadcast Band, bend the slotted plates on Mixer section of the Tuning Condenser for maximum output.

3. SHORT WAVE BAND ALIGNMENT

- (a) Turn the Band Switch (Right hand knob) to Short Wave position and set the Signal Generator to 15 Megacycles and the Tuning Condenser for a corresponding dial reading.
- (b) Adjust the Short Wave Oscillator Trimmer situated on the top right side of chassis through the centre opening until maximum deflection is obtained determining also that set is peaked to the "Fundamental" signal and not the "Image". This may be checked by rotating the Tuning Condenser to approximately 14.1 Megacycles where the "Image" should be observed.
- (c) Set the Generator to 12 Megacycles and the Tuning Condenser for a corresponding dial reading and adjust the Short Wave Mixer Trimmer situated on the top right side of chassis through the opening nearest the front for maximum deflection on the Output Meter.
- (d) Set the Generator to 6 Megacycles and check that the signal is observed when the Tuning Condenser is at a corresponding dial reading; if not, bend the slotted plates on the Oscillator section of the Tuning Condenser, but bear in mind that any adjustments to this section will produce an alteration on the Broadcast band and re-adjustment of the slotted plates on mixer section of tuning condenser may be necessary.

