

MODEL 260
SCHEMATIC
WIRING DIAGRAM

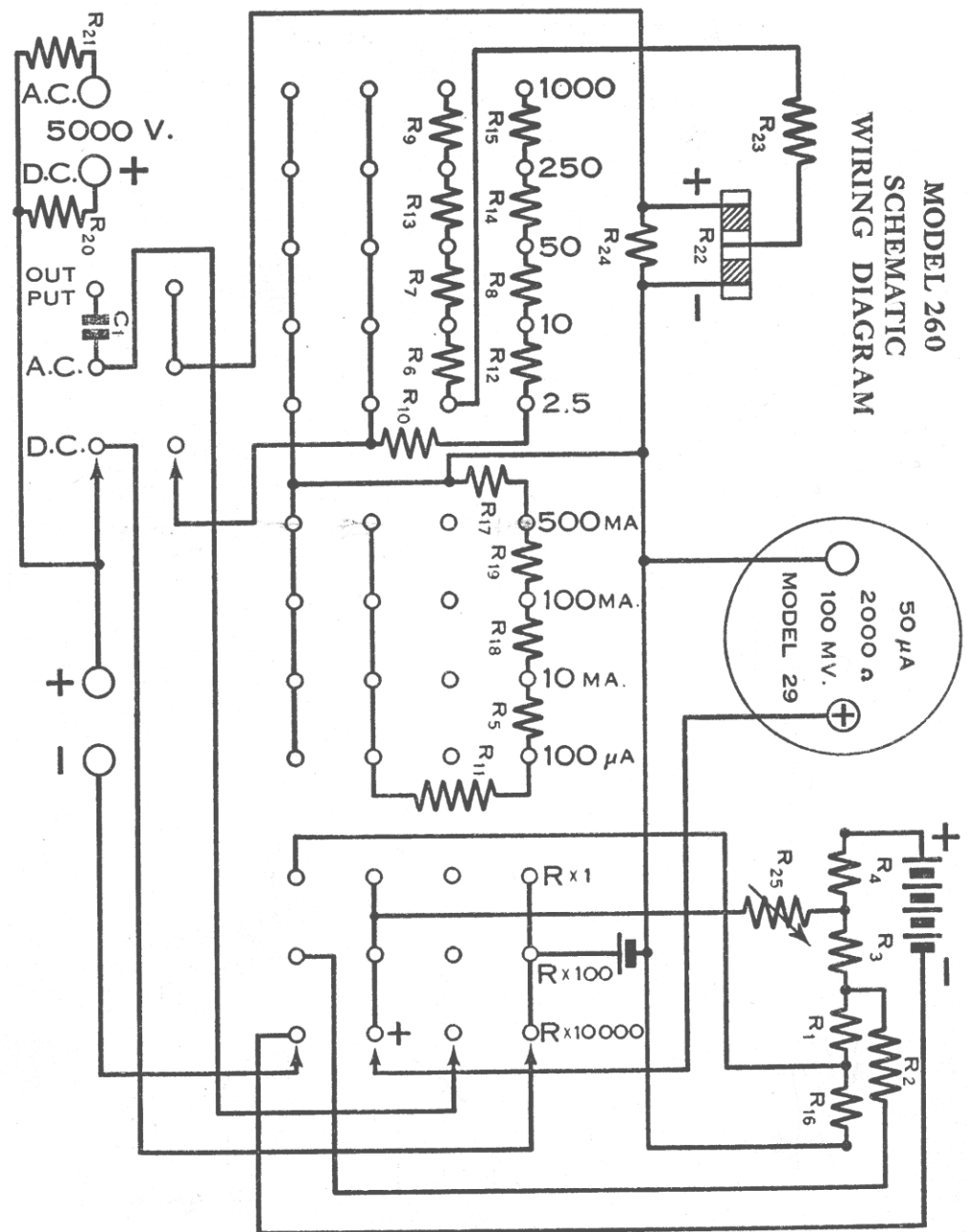

NOTE: MOVING CONTACTS INDICATED BY ARROWS

Figure 9 Model 260 Schematic Diagram

R1	1138 Ω
R2	110 Ω
R3	21,850 Ω
R4	117,700 Ω
R5	4,950 Ω
R6	7,500 Ω
R7	40K Ω
R8	800 K Ω
R9	750K Ω
R10	48 K Ω
R11	3000 Ω
R12	150K Ω
R13	200K Ω
R14	4 M Ω
R15	15M Ω
R16	11.5 Ω
R17	1 Ω
R18	45 Ω
R19	4 Ω
R20	80 M Ω
R21	4 M Ω
R22	RECTIFIER
R23	RECT. SERIES
R24	RECT. SHUNT
R25	10K Ω POT.
C1	0.1 MF. COND.